

35821-G01

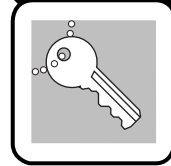

a **TEXTRON** Company



OWNER'S MANUAL AND SERVICE GUIDE

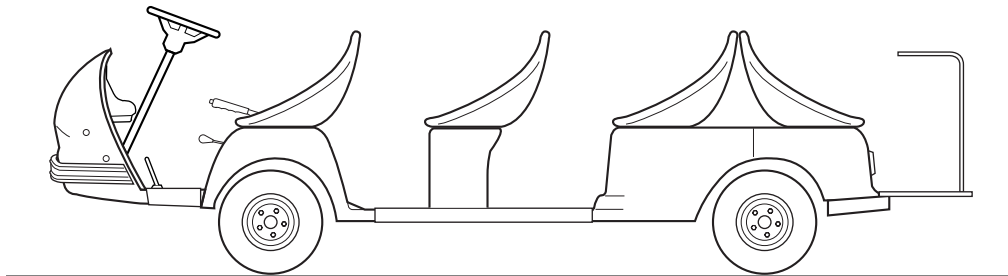
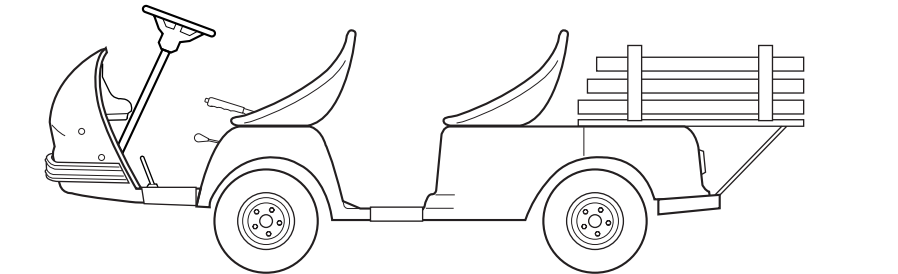
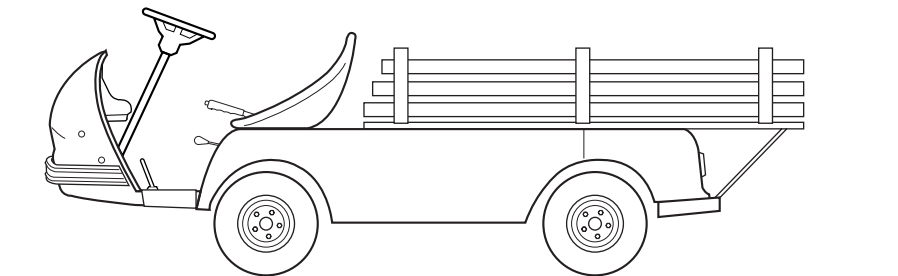

ELECTRIC CARGO AND PERSONNEL CARRIERS (950 SERIES)

ISSUED APRIL 2005

SAFETY

Read and understand all labels located on the vehicle. For any questions on any of the information, contact an E-Z-GO representative for clarification.

Always replace any damaged or missing labels.

On steep hills it is possible for vehicles to coast at greater than normal speeds encountered on a flat surface. To prevent loss of vehicle control and possible serious injury, speeds should be limited to no more than the maximum speed on level ground. (See vehicle specification.) Limit speed by applying the service brake.

Catastrophic damage to the drive train components due to excessive speed may result from driving the vehicle above specified speed. Damage caused by excessive speed may cause a loss of vehicle control, is costly, is considered abuse and will not be covered under warranty.

If the vehicle is to be used in a commercial environment, signs similar to the ones illustrated should be used to warn of situations that could result in an unsafe condition.

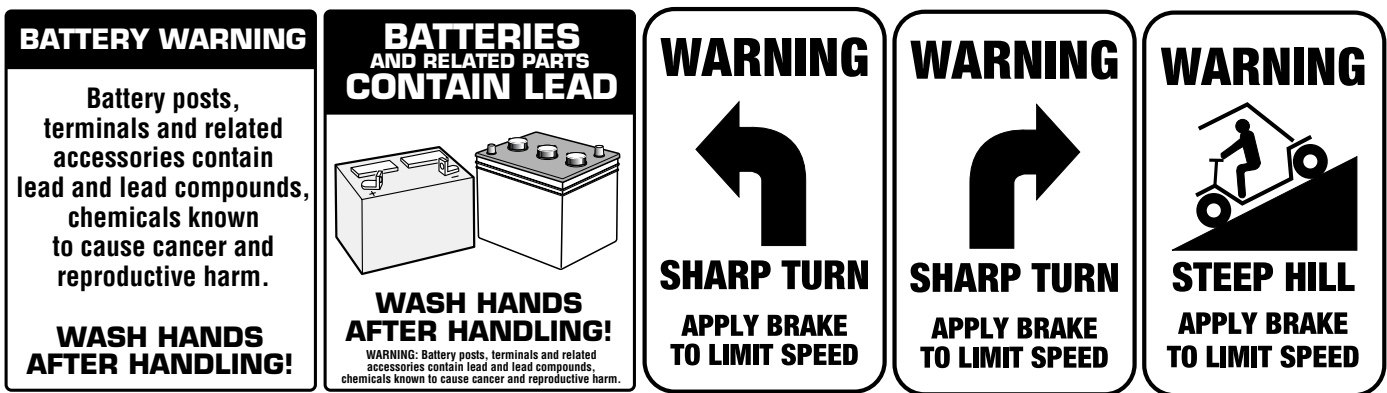

Be sure that this manual remains as part of the permanent service record should the vehicle be resold.

NOTES, CAUTIONS AND WARNINGS

Throughout this guide **NOTE**, **CAUTION** and **WARNING** will be used.

NOTE A **NOTE** indicates a condition that should be observed.

CAUTION A **CAUTION** indicates a condition that may result in damage to the vehicle.

WARNING A **WARNING** indicates a hazardous condition that could result in severe injury or death.

Please observe these **NOTES**, **CAUTIONS** and **WARNINGS**; be aware that servicing a vehicle requires mechanical skill and a regard for conditions that could be hazardous. Improper service or repair may damage the vehicle or render it unsafe.

WARNING Battery posts, terminals and related accessories contain lead and lead compounds. Wash hands after handling.

(NOTES, CAUTIONS AND WARNINGS CONTINUED ON INSIDE OF BACK COVER)

OWNER'S MANUAL AND SERVICE GUIDE

ELECTRIC CARGO AND PERSONNEL CARRIERS (950 SERIES)

VEHICLES

SHUTTLE 952E

SHUTTLE 954E

SHUTTLE 955E

SHUTTLE 956E

SHUTTLE 957E

Starting Model Year 1999

E-Z-GO Division of TEXTRON, Inc. reserves the right to make design changes without obligation to make these changes on units previously sold and the information contained in this manual is subject to change without notice.

E-Z-GO Division of TEXTRON, Inc. is not liable for errors in this manual or for incidental or consequential damages that result from the use of the material in this manual.

TO CONTACT US

NORTH AMERICA:

TECHNICAL ASSISTANCE & WARRANTY PHONE: 1-800-774-3946, FAX: 1-800-448-8124

SERVICE PARTS PHONE: 1-888-GET-EZGO (1-888-438-3946), FAX: 1-800-752-6175

INTERNATIONAL:

PHONE: 010-1-706-798-4311, FAX: 010-1-706-771-4609

E-Z-GO DIVISION OF TEXTRON, INC., 1451 MARVIN GRIFFIN ROAD, AUGUSTA, GEORGIA USA 30906-3852



NOTES

To obtain a copy of the limited warranty applicable to the vehicle, call or write a local distributor, E-Z-GO Branch or the E-Z-GO Warranty Department with vehicle serial number and manufacturer code.

The use of non E-Z-GO parts may void the warranty.

Overfilling of batteries may void the warranty.

BATTERY PROLONGED STORAGE

All batteries will self discharge over time. The rate of self discharge varies depending on the ambient temperature and the age and condition of the batteries.

A fully charged battery will not freeze in winter temperatures unless the temperature falls below -75°F (-60°C).

As with all electric vehicles, the batteries must be checked and recharged as required or at a minimum of 30 day intervals.

TABLE OF CONTENTS

BEFORE INITIAL USE	1
<i>Fig. 1 Initial Service Chart</i>	1
Portable Charger Installation	1
<i>Fig. 2 Charger Installation</i>	1
<i>Fig. 3 Polarized Receptacle</i>	2
On-board Charger	2
<i>Fig. 4 On-board Charger</i>	2
<i>Fig. 5 Cord Storage Compartment</i>	2
ROLL OUT BATTERY TRAY	3
Battery Tray Removal	3
<i>Fig. 6 Accessing Roll Out Battery Tray</i>	3
36V Battery Tray Installation.....	3
48V Battery Tray Installation.....	3
SERIAL NUMBER PLATE LOCATION	3
CONTROLS AND METERS	3
<i>Fig. 7 Serial Number Plate Location</i>	4
Key/Light Switch	4
<i>Fig. 8 Key/Light Switch, State of Charge Meter and Hour Meter</i>	4
State of Charge Meter	4
Hour Meter (Optional)	4
Direction Selector	4
Parking Brake	4
Accelerator Pedal	4
<i>Fig. 9 Direction Selector and Parking Brake</i>	5
<i>Fig. 10 Accelerator, Service Brake and Horn</i>	5
Service Brake Pedal	5
Horn	5
BEFORE ENTERING VEHICLE	5
OPERATING THE VEHICLE	5
Starting the Vehicle on a Hill	6
COASTING	6
SERVICING THE VEHICLE	6
LIFTING THE VEHICLE	6
<i>Fig. 11 Lifting the Vehicle</i>	7
ROUTINE MAINTENANCE	7
<i>Fig. 12 Lubrication Points</i>	7
REAR AXLE	7
Checking the Lubricant Level	8
<i>Fig. 13 Add, Check and Drain Rear Axle Lubricant</i>	8
BRAKES	8
DAILY BRAKE TEST	8
<i>Fig. 14 Accessing Master Cylinder</i>	8
TIRES	8
Tire Repair	9
Wheel Installation	9
<i>Fig. 15 Wheel Installation</i>	10
LIGHT BULB REPLACEMENT	10
CARE AND CLEANING OF THE VEHICLE	10

TABLE OF CONTENTS

TOP AND WINDSHIELD	10
TRAILERING	11
HARDWARE	11
<i>Fig. 16 Bolt Grades</i>	11
TORQUE SPECIFICATIONS	12
<i>Fig. 17 Torque Specifications</i>	12
PERIODIC SERVICE SCHEDULE	13
<i>Fig. 18 Periodic Service Schedule</i>	13
BATTERIES AND CHARGING	15
Safety	15
BATTERY	15
BATTERY MAINTENANCE	15
At Each Charging Cycle	15
Monthly	16
Electrolyte Level and Water	16
<i>Fig. 19 Correct Electrolyte Level</i>	16
<i>Fig. 20 Water Purity Table</i>	16
<i>Fig. 21 Automatic Watering Gun</i>	17
Cleaning Batteries	17
<i>Fig. 22 Preparing Acid Neutralizing Solution</i>	17
Battery Replacement	17
<i>Fig. 23 Battery Connections (36V Systems)</i>	18
<i>Fig. 24 Battery Connections (48V Systems)</i>	18
Prolonged Storage	19
Battery Charging	19
<i>Fig. 25 Freezing Point of Electrolyte</i>	19
AC Voltage	20
TROUBLESHOOTING	20
Hydrometer	20
<i>Fig. 26 Hydrometer</i>	20
Using A Hydrometer	21
<i>Fig. 27 Hydrometer Temperature Correction</i>	21
BATTERY CHARGER MAINTENANCE	21
<i>Fig. 28 Cleaning Auxiliary Contact in Charger Plug</i>	21
GENERAL SPECIFICATIONS.....	23
SHUTTLE 952E	24
SHUTTLE 954E	25
SHUTTLE 955E	26
SHUTTLE 956E	27
SHUTTLE 957E	28
<i>Fig. 29 952, 954 and 956 Vehicle Dimensions</i>	29
<i>Fig. 30 955 and 957 Vehicle Dimensions</i>	30
<i>Fig. 31 Vehicle Dimensions and Incline Specifications</i>	31
<i>Fig. 32 Vehicle Turning Clearance Diameter</i>	32



SAFETY INFORMATION

This manual has been designed to assist the owner-operator in maintaining the vehicle in accordance with procedures developed by the manufacturer. Adherence to these procedures and troubleshooting tips will ensure the best possible service from the product. To reduce the chance of personal injury and/or property damage, the following instructions must be carefully observed:

CAUTION

Certain replacement parts can be used independently and/or in combination with other accessories to modify an E-Z-GO-manufactured vehicle to permit the vehicle to operate at or in excess of 20mph. When an E-Z-GO-manufactured vehicle is modified in any way by the Distributor, Dealer or customer to operate at or in excess of 20mph, UNDER FEDERAL LAW the modified product will be a Low Speed Vehicle (LSV) subject to the strictures and requirements of Federal Motor Vehicle Safety Standard 571.500. In these instances, pursuant to Federal law the Distributor or Dealer MUST equip the product with headlights, rear lights, turn signals, seat belts, top, horn and all other modifications for LSV's mandated in FMVSS 571.500, and affix a Vehicle Identification Number to the product in accordance with the requirements of FMVSS 571.565. Pursuant to FMVSS 571.500, and in accordance with the State laws applicable in the places of sale and use of the product, the Distributor, Dealer or customer modifying the vehicle also will be the Final Vehicle Manufacturer for the LSV, and required to title or register the vehicle as mandated by State law.

E-Z-GO will NOT approve Distributor, Dealer or customer modifications converting E-Z-GO products into LSV's.

The Company, in addition, recommends that all E-Z-GO products sold as personal transportation vehicles BE OPERATED ONLY BY PERSONS WITH VALID DRIVERS LICENSES, AND IN ACCORDANCE WITH APPLICABLE STATE REQUIREMENTS. This restriction is important to the SAFE USE AND OPERATION of the product. On behalf of E-Z-GO, I am directing that E-Z-GO Branch personnel, Distributors and Dealers advise all customers to adhere to this SAFETY RESTRICTION, in connection with the use of all products, new and used, the Distributor or Dealer has reason to believe may be operated in personal transportation applications.

Information on FMVSS 571.500 can be obtained at Title 49 of the Code of Federal Regulations, section 571.500, or through the Internet at the website for the U.S. Department of Transportation - at Dockets and Regulation, then to Title 49 of the Code of Federal Regulations (Transportation).

GENERAL

Many vehicles are used for a variety of tasks beyond the original intended use of the vehicle; therefore it is impossible to anticipate and warn against every possible combination of circumstances that may occur. No warnings can take the place of good common sense and prudent driving practices.

Good common sense and prudent driving practices do more to prevent accidents and injury than all of the warnings and instructions combined. E-Z-GO strongly suggests that the owner-operator read this entire manual paying particular attention to the CAUTIONS and WARNINGS contained therein. It is further recommended that employees and other operators be encouraged to do the same.

If you have any questions, contact your closest E-Z-GO representative or write to the address on the back cover of this publication, Attention: Product Service Department.

E-Z-GO Division of Textron reserves the right to make design changes without obligation to make these changes on units previously sold and the information contained in this manual is subject to change without notice.

E-Z-GO Division of Textron is not liable for errors in this manual or for incidental or consequential damages that result from the use of the material in this manual.



SAFETY INFORMATION

This vehicle conforms to the current applicable standard for safety and performance requirements.

These vehicles are designed and manufactured for off-road use. They do not conform to Federal Motor Vehicle Safety Standards and are not equipped for operation on public streets. Some communities may permit these vehicles to be operated on their streets on a limited basis and in accordance with local ordinances.

With electric powered vehicles, be sure that all electrical accessories are grounded directly to the battery (-) post. **Never use the chassis or body as a ground connection.**

Refer to GENERAL SPECIFICATIONS for vehicle seating capacity.

Never modify the vehicle in any way that will alter the weight distribution of the vehicle, decrease its stability or increase the speed beyond the factory specification. Such modifications can cause serious personal injury or death. Modifications that increase the speed and/or weight of the vehicle will extend the stopping distance and may reduce the stability of the vehicle. Do not make any such modifications or changes. E-Z-GO prohibits and disclaims responsibility for any such modifications or any other alteration which would adversely affect the safety of the vehicle.

Vehicles that are capable of higher speeds must limit their speed to no more than the speed of other vehicles when used in a golf course environment. Additionally, speed should be further moderated by the environmental conditions, terrain and common sense.

GENERAL OPERATION

Always use the vehicle in a responsible manner and maintain the vehicle in safe operating condition.

Always read and observe all warnings and operation instruction labels affixed to the vehicle.

Always follow all safety rules established in the area where the vehicle is being operated.

Always reduce speed to compensate for poor terrain or conditions.

Always apply service brake to control speed on steep grades.

Always maintain adequate distance between vehicles.

Always reduce speed in wet areas.

Always use extreme caution when approaching sharp or blind turns.

Always use extreme caution when driving over loose terrain.

Always use extreme caution in areas where pedestrians are present.

MAINTENANCE

Always maintain your vehicle in accordance with the manufacturer's periodic service schedule.

Always ensure that mechanics performing repairs are trained and qualified to do so.

Always follow the manufacturer's directions if you do any maintenance on your vehicle. Be sure to disable the vehicle before performing any maintenance. Disabling includes removing the key from the key switch and removal of a battery wire.

Always insulate any tools used within the battery area in order to prevent sparks or battery explosion caused by shorting the battery terminals or associated wiring. Remove the batteries or cover exposed terminals with an insulating material.

SAFETY INFORMATION

Always check the polarity of each battery terminal and be sure to rewire the batteries correctly.

Always use specified replacement parts. Never use replacement parts of lesser quality.

Always use recommended tools.

Always determine that tools and procedures not specifically recommended by the manufacturer will not compromise the safety of personnel nor jeopardize the safe operation of the vehicle.

Always support the vehicle using wheel chocks and safety stands. Never get under a vehicle that is supported by a jack. Lift the vehicle in accordance with the manufacturer's instructions.

Never attempt to maintain a vehicle in an area where exposed flame is present or persons are smoking.

Always be aware that a vehicle that is not performing as designed is a potential hazard and must not be operated.

The manufacturer cannot anticipate all situations, therefore people attempting to maintain or repair the vehicle must have the skill and experience to recognize and protect themselves from potential situations that could result in severe personal injury or death and damage to the vehicle. Use extreme caution and, if unsure as to the potential for injury, refer the repair or maintenance to a qualified mechanic.

Always test drive the vehicle after any repairs or maintenance. All tests must be conducted in a safe area that is free of both vehicular and pedestrian traffic.

Always replace damaged or missing warning, caution or information labels.

Always keep complete records of the maintenance history of the vehicle.

VENTILATION

Hydrogen gas is generated in the charging cycle of batteries and is explosive in concentrations as low as 4%. Because hydrogen gas is lighter than air, it will collect in the ceiling of buildings necessitating proper ventilation. Five air exchanges per hour is considered the minimum requirement.

Never charge a vehicle in an area that is subject to flame or spark. Pay particular attention to natural gas or propane gas water heaters and furnaces.

Always use a dedicated circuit for each battery charger. Do not permit other appliances to be plugged into the receptacle when the charger is in operation.

Chargers must be installed and operated in accordance with charger manufacturers recommendations or applicable electrical code (whichever is more restrictive).

SAFETY INFORMATION

Read all of manual to become thoroughly familiar with this vehicle. Pay particular attention to all Notes, Cautions and Warnings

GENERAL

The following text is provided as recommended by part II of ASME/ANSI B56.8-1988. E-Z-GO strongly endorses the contents of this specification.

PART II FOR THE USER

4 GENERAL SAFETY PRACTICES

4.1 Introduction

4.1.1 Like other machines, carriers can cause injury if improperly used or maintained. Part II contains broad safety practices applicable to carrier operations. Before operation, the user shall establish such additional specific safety practices as may reasonably be required for safe operation.

4.2 Stability

4.2.1 Experience has shown that this vehicle, which complies with this standard, is stable when properly operated and when operated in accordance with specific safety rules and practices established to meet actual operating terrain and conditions. However, improper operation, faulty maintenance, or poor housekeeping may contribute to a condition of instability and defeat the purpose of the standard. Some of the conditions which may affect stability are failure of the user to follow safety practices; also, ground and floor conditions, grade, speed, loading, the operation of the carrier with improper loads, battery weight, dynamic and static forces, and the judgement exercised by the carrier operator.

(a) The user shall train carrier operators to adhere strictly to the operating instructions stated in this Standard.

(b) The user shall survey specific operating conditions and environment, and establish and train carrier operators to comply with additional, specific safety practices.

4.3 Nameplates, Markings, Capacity, and Modifications

4.3.1 The user shall maintain in a legible condition all nameplates, warnings, and instructions which are supplied by the manufacturer.

4.3.2 The user shall not perform any modification or addition which affects capacity or safe operation, or make any change not in accordance with the owner's

manual without the manufacturer's prior written authorization. Where authorized modifications have been made, the user shall ensure that capacity, operation, warning, and maintenance instruction plates, tags, or decals are changed accordingly.

4.3.3 As required under paras. 4.3.1 or 4.3.2, the manufacturer shall be contacted to secure new nameplates, warnings, or instructions which shall then be affixed in their proper place on the carrier.

4.4 Fuel Handling and Storage

4.4.1 The user shall supervise the storage and handling of liquid fuels (when used) to be certain that it is in accordance with appropriate paragraphs of ANSI/NFPA 505 and ANSI/NFPA 30.

4.4.2 Storage and handling of liquefied petroleum gas fuels shall be in accordance with appropriate paragraphs of ANSI/NFPA 505 and ANSI/NFPA 58. If such storage or handling is not in compliance with these standards, the user shall prevent the carrier from being used until such storage and handling is in compliance with these standards.

4.5 Changing and Charging Storage Batteries for Electric Personnel and Burden Carriers

4.5.1 The user shall require battery changing and charging facilities and procedures to be in accordance with appropriate paragraphs of ANSI/NFPA 505.

4.5.2 The user shall periodically inspect facilities and review procedures to be certain that appropriate paragraphs of ANSI/NFPA 505, are strictly complied with, and shall familiarize carrier operators with it.

4.6 Hazardous Locations

4.6.1 The user shall determine the hazard classification of the particular atmosphere or location in which the carrier is to be used in accordance with ANSI/NFPA 505.

4.6.2 The user shall permit in hazardous areas only those carriers approved and of the type required by ANSI/NFPA 505.

4.7 Lighting for Operating Areas

4.7.1 The user, in accordance with his responsibility to survey the environment and operating conditions, shall determine if the carrier requires lights and, if so, shall equip the carrier with appropriate lights in accordance with the manufacturer's recommendations.



SAFETY INFORMATION

Read all of manual to become thoroughly familiar with this vehicle. Pay particular attention to all Notes, Cautions and Warnings

4.8 Control of Noxious Gases and Fumes

4.8.1 When equipment powered by internal combustion engines is used in enclosed areas, the atmosphere shall be maintained within limits specified in the American Conference of Governmental Industrial Hygienists publication, "Threshold Limit Values for Chemical Substances and Physical Agents in the Workroom Environment". This shall be accomplished by ventilation provided by the user, and/or the installation, use, and proper maintenance of emission control equipment recommended or provided by the manufacturer of the equipment.

4.9 Warning Device(s)

4.9.1 The user shall make periodic inspections of the carrier to be certain that the sound-producing and/or visual device(s) are maintained in good operating condition.

4.9.2 The user shall determine if operating conditions require the carrier to be equipped with additional sound-producing and/or visual devices and be responsible for providing and maintaining such devices, in accordance with the manufacturer's recommendations.

5 OPERATING SAFETY RULES AND PRACTICES

5.1 Personnel and Burden Carrier Operator Qualifications

5.1.1 Only persons who are trained in the proper operation of the carrier shall be authorized to operate the carrier. Operators shall be qualified as to visual, auditory, physical, and mental ability to safely operate the equipment according to Section 5 and all other applicable parts of this Standard.

5.2 Personnel and Burden Carrier Operators' Training

5.2.1 The user shall conduct an operators' training program.

5.2.2 Successful completion of the operators' training program shall be required by the user before operation of the carrier. The program shall be presented in its entirety to all new operators and not condensed for those claiming previous experience.

5.2.3 The user should include in the operators' training program the following:

- (a) instructional material provided by the manufac-

turer;

- (b) emphasis on safety of passengers, material loads, carrier operator, and other employees;

- (c) general safety rules contained within this Standard and the additional specific rules determined by the user in accordance with this Standard, and why they were formulated;

- (d) introduction of equipment, control locations and functions, and explanation of how they work when used properly and when used improperly, and surface conditions, grade, and other conditions of the environment in which the carrier is to be operated;

- (e) operational performance tests and evaluations during, and at completion of, the program.

5.3 Personnel and Burden Carrier Operator Responsibility

5.3.1 Operators shall abide by the following safety rules and practices in paras. 5.4, 5.5, 5.6, and 5.7.

5.4 General

5.4.1 Safeguard the pedestrians at all times. Do not drive carrier in a manner that would endanger anyone.

5.4.2 Riding on the carrier by persons other than the operator is authorized only on personnel seat(s) provided by the manufacturer. All parts of the body shall remain within the plan view outline of the carrier.

5.4.3 When a carrier is to be left unattended, stop carrier, apply the parking brake, stop the engine or turn off power, turn off the control or ignition circuit, and remove the key if provided. Block the wheels if machine is on an incline.

5.4.4 A carrier is considered unattended when the operator is 25 ft. (7.6 m) or more from the carrier which remains in his view, or whenever the operator leaves the carrier and it is not within his view. When the operator is dismounted and within 25 ft. (7.6 m) of the carrier still in his view, he still must have controls neutralized, and the parking brake(s) set to prevent movement.

5.4.5 Maintain a safe distance from the edge of ramps and platforms.

5.4.6 Use only approved carriers in hazardous locations, as defined in the appropriate safety standards.

5.4.7 Report all accidents involving personnel, building structures, and equipment.

5.4.8 Operators shall not add to, or modify, the carrier.



SAFETY INFORMATION

Read all of manual to become thoroughly familiar with this vehicle. Pay particular attention to all Notes, Cautions and Warnings

5.4.9 Carriers shall not be parked or left unattended such that they block or obstruct fire aisles, access to stairways, or fire equipment.

5.5 Traveling

5.5.1 Observe all traffic regulations, including authorized speed limits. Under normal traffic conditions keep to the right. Maintain a safe distance, based on speed of travel, from a carrier or vehicle ahead; and keep the carrier under control at all times.

5.5.2 Yield the right of way to pedestrians, ambulances, fire trucks, or other carriers or vehicles in emergency situations.

5.5.3 Do not pass another carrier or vehicle traveling in the same direction at intersections, blind spots, or at other dangerous locations.

5.5.4 Keep a clear view of the path of travel, observe other traffic and personnel, and maintain a safe clearance.

5.5.5 Slow down or stop, as conditions dictate, and activate the sound-producing warning device at cross aisles and when visibility is obstructed at other locations.

5.5.6 Ascend or descend grades slowly.

5.5.7 Avoid turning, if possible, and use extreme caution on grades, ramps, or inclines; normally travel straight up and down.

5.5.8 Under all travel conditions the carrier shall be operated at a speed that will permit it to be brought to a stop in a safe manner.

5.5.9 Make starts, stops, turns, or direction reversals in a smooth manner so as not to shift the load, endanger passengers, or overturn the carrier.

5.5.10 Do not indulge in dangerous activities, such as stunt driving or horseplay.

5.5.11 Slow down when approaching, or on, wet or slippery surfaces.

5.5.12 Do not drive carrier onto any elevator unless specifically authorized to do so. Approach elevators slowly, and then enter squarely after the elevator car is properly leveled. Once on the elevator, neutralize the controls, shut off power, and set parking brakes. It is advisable that all other personnel leave the elevator before a carrier is allowed to enter or exit.

5.5.13 Avoid running over loose objects, potholes, and bumps.

5.5.14 To negotiate turns, reduce speed to improve stability, then turn hand steering wheel or tiller in a

smooth, sweeping motion.

5.6 Loading

5.6.1 Handle only stable and safely arranged loads. When handling off-center loads which cannot be centered, operate with extra caution.

5.6.2 Handle only loads within the capacity of the carrier as specified on the nameplate.

5.6.3 Handle loads exceeding the dimensions used to establish carrier capacity with extra caution. Stability and maneuverability may be adversely affected.

5.7 Operator Care of Personnel and Burden Carriers

5.7.1 At the beginning of each shift during which the carrier will be used, the operator shall check the carrier condition and inspect the tires, warning devices, lights, battery(s), speed and directional controllers, brakes, and steering mechanism. If the carrier is found to be in need of repair, or in any way unsafe, the matter shall be reported immediately to the designated authority and the carrier shall not be operated until it has been restored to safe operating condition.

5.7.2 If during operation the carrier becomes unsafe in any way, the matter shall be reported immediately to the designated authority, and the carrier shall not be operated until it has been restored to safe operating condition.

5.7.3 Do not make repairs or adjustments unless specifically authorized to do so.

5.7.4 The engine shall be stopped and the operator shall leave the carrier while refueling.

5.7.5 Spillage of oil or fuel shall be carefully and completely absorbed or evaporated and fuel tank cap replaced before starting engine.

5.7.6 Do not operate a carrier with a leak in the fuel system or battery(s).

5.7.7 Do not use open flames for checking electrolyte level in storage battery(s) or liquid level in fuel tanks.

6 MAINTENANCE PRACTICES

6.1 Introduction

6.1.1 Carriers may become hazardous if maintenance is neglected. Therefore, maintenance facilities, trained personnel, and procedures shall be provided. Such facilities may be on or off the premises.



SAFETY INFORMATION

Read all of manual to become thoroughly familiar with this vehicle. Pay particular attention to all Notes, Cautions and Warnings

6.2 Maintenance Procedures

6.2.1 Maintenance and inspection of all carriers shall be performed in conformance with the manufacturer's recommendations and the following practices.

(a) A scheduled preventive maintenance, lubrication, and inspection system shall be followed.

(b) Only qualified and authorized personnel shall be permitted to maintain, repair, adjust, and inspect carriers.

(c) Before undertaking maintenance or repair, follow the manufacturer's recommendations for immobilizing the carrier.

(d) Block chassis before working underneath it.

(e) Before disconnecting any part of the engine fuel system of a gasoline or diesel powered carrier with gravity feed fuel systems, be sure shutoff valve is closed, and run engine until fuel system is depleted and engine stops running.

(f) Before disconnecting any part of the engine fuel system of LP gas powered carriers, close the LP gas cylinder valve and run the engine until fuel in the system is depleted and the engine stops running.

(g) Operation to check performance of the carrier shall be conducted in an authorized area where safe clearance exists.

(h) Before commencing operation of the carrier, follow the manufacturer's instructions and recommended procedures.

(i) Avoid fire hazards and have fire protection equipment present in the work area. Do not use an open flame to check level or leakage of fuel, battery electrolyte, or coolant. Do not use open pans of fuel or flammable cleaning fluids for cleaning parts.

(j) Properly ventilate the work area.

(k) Handle LP gas cylinders with care. Physical damage, such as dents, scrapes, or gouges, may dangerously weaken the tank and make it unsafe for use.

(l) Brakes, steering mechanisms, speed and directional control mechanisms, warning devices, lights, governors, guards, and safety devices shall be inspected regularly and maintained in a safe operating condition.

(m) Special carriers or devices designed and approved for hazardous area operation shall be inspected to ensure that maintenance preserves the original approved safe operating features.

(n) Fuel systems shall be checked for leaks and condition of parts. If a leak is found, action shall be taken to

prevent the use of the carrier until the leak has been eliminated.

(o) The carrier manufacturer's capacity, operation, and maintenance instruction plates, tags, or decals shall be maintained in legible condition.

(p) Batteries, motors, speed and directional controllers, limit switches, protective devices, electrical conductors, and connections shall be inspected and maintained in conformance with manufacturers recommended procedures.

(q) Carriers shall be kept in a clean condition to minimize fire hazards and facilitate detection of loose or defective parts.

(r) Modifications and additions which affect capacity and safe machine operation shall not be performed by the customer or user without manufacturer's prior written authorization; where authorized modifications have been made, the user shall ensure that capacity, operation, warning, and maintenance instruction plates, tags, or decals are changed accordingly.

(s) Care shall be taken to ensure that all replacement parts are interchangeable with the original parts and of a quality at least equal to that provided in the original equipment.

ELECTRIC CARGO AND PERSONNEL CARRIERS

Read all of manual to become thoroughly familiar with this vehicle. Pay particular attention to all Notes, Cautions and Warnings

Thank you for purchasing an E-Z-GO vehicle. This vehicle is equipped with an electronic speed control unit that is the most advanced in the industry. Before driving the vehicle, we ask you to spend some time reading this Owner's Manual and Service Guide. This guide contains information that will assist you in maintaining your highly reliable vehicle. Some illustrations may show items that are optional for your vehicle.

Most of the service procedures in this guide can be accomplished by the individual owner using common automotive hand tools. Refer to an E-Z-GO service representative for information on servicing the vehicle in accordance with the Periodic Service Schedule.

To facilitate maintenance, a Service Parts Manual and a Technician's Repair and Service Manual is available from a local Distributor, an E-Z-GO Branch or the E-Z-GO Service Parts Department. When ordering parts or requesting information for your vehicle, provide vehicle model, serial number and manufacture code.

BEFORE INITIAL USE

Be sure you understand the vehicle, its equipment and how to use it safely. Although E-Z-GO vehicles have been designed to provide safe and reliable operation, maintaining good performance depends to a large extent on the operator.

⚠ WARNING ⚠ *Hydrogen gas is generated as a natural part of the charging process. A 4% concentration of hydrogen gas is explosive. Charging must take place in an area that is adequately ventilated. (Minimum of 5 air exchanges per hour).*

Never charge batteries in an area that has open flame or electrical equipment that could cause an electrical arc.

Never smoke around batteries.

Before a new vehicle is put into operation, it is recommended that the items shown in the INITIAL SERVICE CHART be performed (Ref Fig. 1 on page 1).

Vehicle batteries must be fully charged before initial use.

ITEM	SERVICE OPERATION
Batteries	Charge batteries
Brakes	Check operation and adjust if necessary
	Check hydraulic brake fluid level
Tires	Check pressure

Fig. 1 Initial Service Chart

Portable Charger Installation

⚠ WARNING ⚠ *Portable chargers should be mounted on a platform above the ground or in such a manner as to permit the maximum air flow underneath and around the charger. Do not block or obstruct the louvers as overheating may result which could cause serious damage to the charger and create the potential for fire.*

If the charger is operated in an outdoor location, rain and sun protection must be provided.

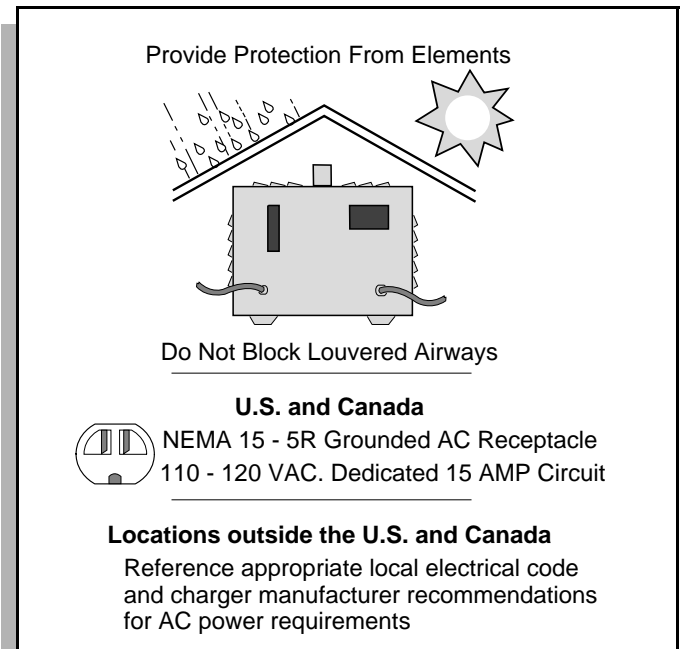

Fig. 2 Charger Installation

ELECTRIC CARGO AND PERSONNEL CARRIERS

Read all of manual to become thoroughly familiar with this vehicle. Pay particular attention to all Notes, Cautions and Warnings

Portable chargers are shipped with the vehicle. Prior to vehicle or charger operation, chargers must be removed and mounted on a platform or wall above the ground to permit maximum air flow around and underneath the charger.

A dedicated 15 amp circuit is required for the charger (Ref Fig. 2 on page 1). The charger may remain plugged into the AC outlet. To charge the vehicle, refer to the instruction labels on the charger. Insert the DC plug completely into the vehicle receptacle (Ref Fig. 3 on page 2). After inserting the polarized DC plug, wait a few seconds and observe ammeter on charger to make sure it moves indicating that charger is charging.

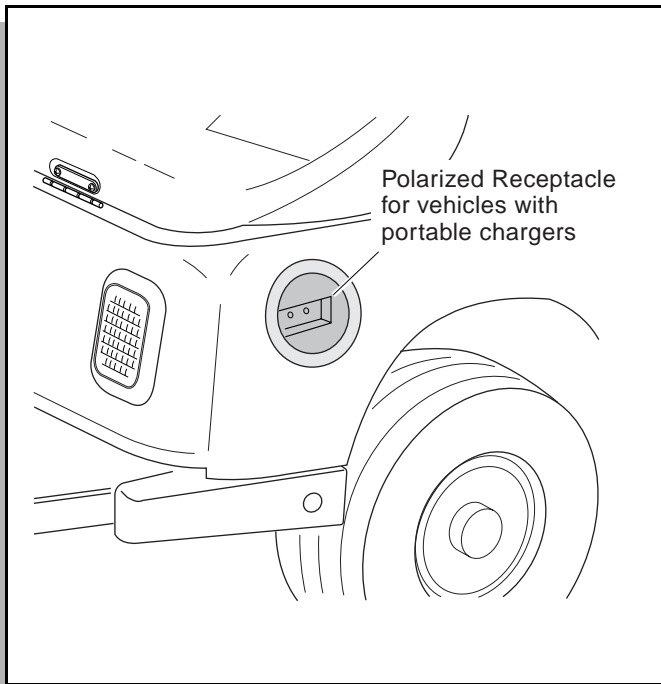

Fig. 3 Polarized Receptacle

The charger will automatically start a few seconds after plug insertion. The charger will automatically stop when batteries are fully charged and the DC plug can be removed to permit use of the vehicle.



An ungrounded electrical device may become a physical hazard that could result in an electrical shock or electrocution.

The power (AC) cord is equipped with a grounded plug, do not attempt to pull out, cut or bend the ground post.



If vehicle is to be charged with a non E-Z-GO charger, refer to the instructions supplied with the charger.

On-board Charger

The on-board charger is located under the rear facing seat (Shuttle 956E and 957E only) or cargo deck at the rear of the vehicle. It is wired directly to the batteries, only requiring it be plugged into a dedicated 15 amp AC outlet to be operational (Ref Fig. 4 on page 2).

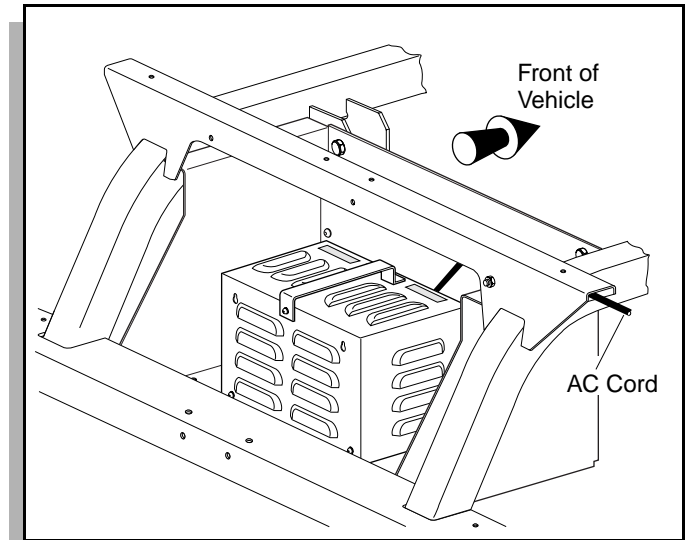

Fig. 4 On-board Charger

When charge cycle is complete, replace cord into the cord storage compartment (Ref Fig. 5 on page 2).

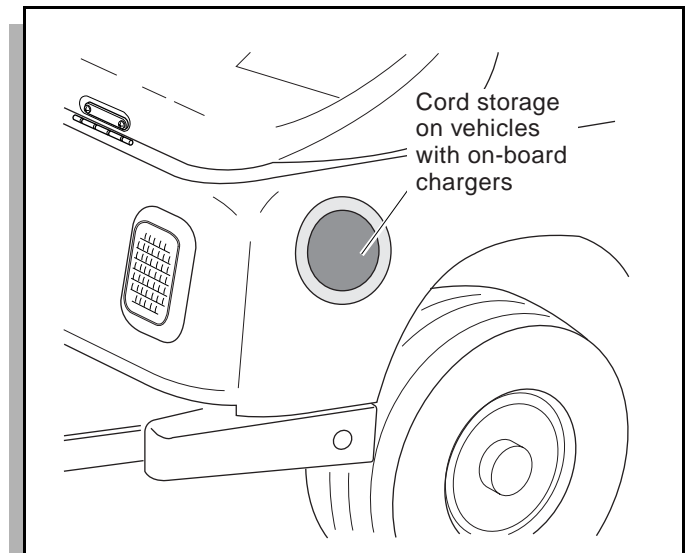

Fig. 5 Cord Storage Compartment

ELECTRIC CARGO AND PERSONNEL CARRIERS

Read all of manual to become thoroughly familiar with this vehicle. Pay particular attention to all Notes, Cautions and Warnings

ROLL OUT BATTERY TRAY

Optional roll out battery trays and dollies allow the vehicle to be operated continuously without taking the vehicle out of service for battery charging.

Battery Tray Removal

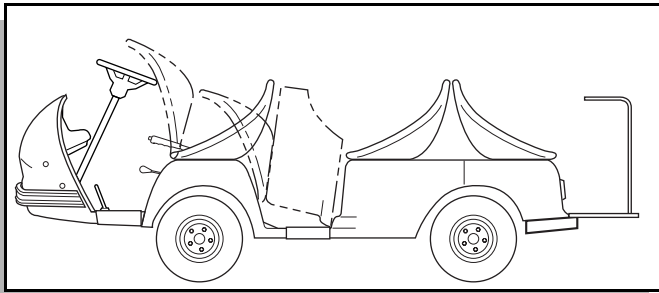

Fig. 6 Accessing Roll Out Battery Tray

To remove the discharged set of batteries, loosen the seat retaining screw in the front seat and tilt seat forward. Locate the latches behind the rear (front facing) seat. Rotate latches using a 1/2" wrench and tilt entire seat and body assembly forward (Ref Fig. 6 on page 3). Move the roll out battery tray dolly into position and fully engage the guide tabs onto the outside of both sides of the vertical walls of the roll out battery tray track. It may be necessary to lift up slightly on the back of the dolly to initially engage the tabs of the dolly. Disconnect the quick disconnect wire harness plug. Disengage the dolly winch lock and play out the winch rope until the snap hook can be hooked into the TOP hole of the battery tray lock pin bracket. Engage the winch lock. Lift up and hold the lock pin to release tray for removal. Pull tray slightly outward and release pin. Stand behind the dolly, and hold the dolly engaged to the vehicle with a foot against one of the dolly's rear support legs (for 48V vehicles brace foot against the dolly's lower, rear horizontal crossmember). Crank the battery tray out of the vehicle and onto the dolly. Move the dolly and battery tray away from the vehicle and to a safe place for charging.

36V Battery Tray Installation

To install a charged 36V battery tray into the vehicle, tilt seats and body assembly forward. Move the roll out battery tray dolly into position and fully engage the guide tabs onto both sides of the vertical walls of the roll out battery tray track. Disengage the dolly winch lock. While standing behind the dolly, and holding the dolly engaged to the vehicle with a foot against one of the dolly's rear support legs, unhook the snap hook and push the battery tray onto the battery tray track. Ensure that the locking pin locks into place. Remove the dolly. Connect the quick

disconnect wire harness plug. Tilt rear (front facing) seat and body assembly back into place and secure latches. Tilt front seat rearward and tighten the seat retaining screw.

48V Battery Tray Installation

To install a charged 48V battery tray into the vehicle, tilt seats and body assembly forward. Move the roll out battery tray dolly into position and fully engage the guide tabs onto both sides of the vertical walls of the roll out battery tray track. Disengage the dolly winch lock and play out enough winch rope to unhook the snap hook from the top hole of the battery tray lock pin bracket and hook it to the BOTTOM hole. Play out enough winch rope to loop the rope around the dolly pulley and take up the slack with the winch handle. Engage the winch lock. Move the roll out battery tray dolly into position and fully engage the guide tabs onto both sides of the vertical walls of the roll out battery tray track. Stand behind the dolly, and hold the dolly engaged to the vehicle with foot against the dolly's lower, rear horizontal crossmember. Crank the battery tray off of the dolly and into the vehicle. Continue to crank until the third set of rollers is well onto the track. Hold the battery tray in the vehicle with one hand and disengage the snap hook with the other. Push the tray into the vehicle fully ensuring that the locking pin locks into place. Remove the dolly. Connect the quick disconnect wire harness plug. Tilt rear (front facing) seat and body assembly back into place and secure latches. Tilt front seat rearward and tighten the seat retaining screw.

SERIAL NUMBER PLATE LOCATION

The serial and manufacturing numbers are located on a plate underneath the dash panel on the passenger side of the vehicle (Ref Fig. 7 on page 4).

Design changes take place on an ongoing basis. In order to obtain correct components for the vehicle, the manufacturing date and serial number must be provided when ordering service parts.

CONTROLS AND METERS

The controls and meters on the vehicle consist of the following:

- key/light switch
- state of charge meter
- hour meter (optional)
- direction selector lever

ELECTRIC CARGO AND PERSONNEL CARRIERS

Read all of manual to become thoroughly familiar with this vehicle. Pay particular attention to all Notes, Cautions and Warnings

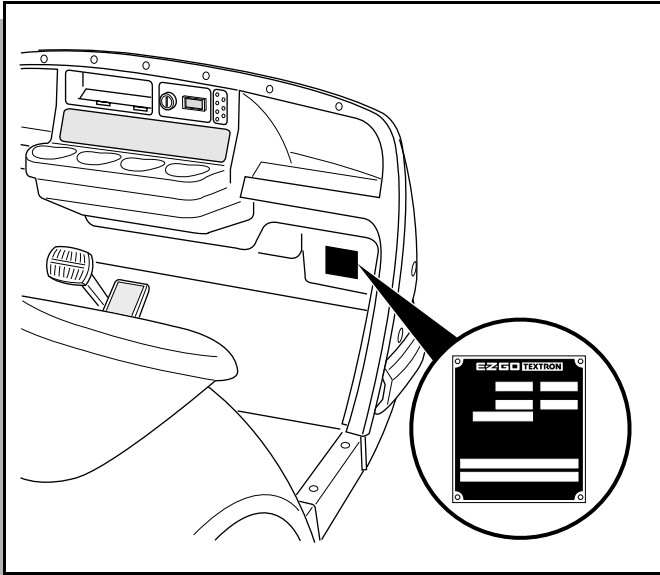

Fig. 7 Serial Number Plate Location

- parking brake
- accelerator pedal
- service brake pedal
- horn

Key/Light Switch

Located on the dash panel, the key/light switch enables the basic electrical system of the vehicle to be turned on and off by turning the key. This switch also has a position for operating the lights. The lights will illuminate only when the key is turned to the light icon position (Ref Fig. 8 on page 4).

To prevent inadvertent operation of the vehicle when left unattended, the key should be turned to the 'OFF' position and removed.

NOTE If the vehicle is equipped with E-Z-GO installed custom accessories, some accessories remain operational with the key switch in the 'OFF' position.

State of Charge Meter

Located on the dash console to the right of the key/light switch, the state of charge meter indicates the amount of usable power in the batteries (Ref Fig. 8 on page 4).

Hour Meter (Optional)

Located on the dash console to the left of the key/light switch, the hour meter indicates total hours of operation (Ref Fig. 8 on page 4).

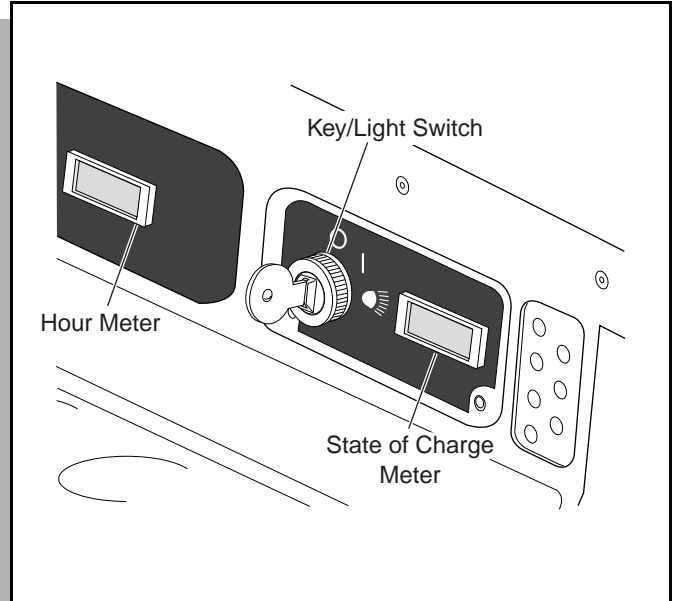

Fig. 8 Key/Light Switch, State of Charge Meter and Hour Meter

Direction Selector

Located on the panel in the center of the front seat, this lever permits the selection of either 'F' (forward) or 'R' (reverse) (Ref Fig. 9 on page 5). It should be left in neutral (position between 'F' and 'R') when the vehicle is unattended.

CAUTION To prevent component damage, the vehicle must be completely stopped before moving the direction selector.

Parking Brake

The hand operated parking brake is located on the panel in the center of the front seat (Ref Fig. 9 on page 5). The brake is engaged when the handle is raised and is disengaged when the handle is parallel to the seat bottom.

When leaving the vehicle unattended, engage the parking brake by raising the handle until it locks in place. To release the parking brake, depress the release button in the end of the handle while slightly raising the handle, then lower the parking brake handle.

Accelerator Pedal

Depressing the accelerator pedal starts the motor. When the pedal is released, the motor will stop (Ref Fig. 10 on page 5).

ELECTRIC CARGO AND PERSONNEL CARRIERS

Read all of manual to become thoroughly familiar with this vehicle. Pay particular attention to all Notes, Cautions and Warnings

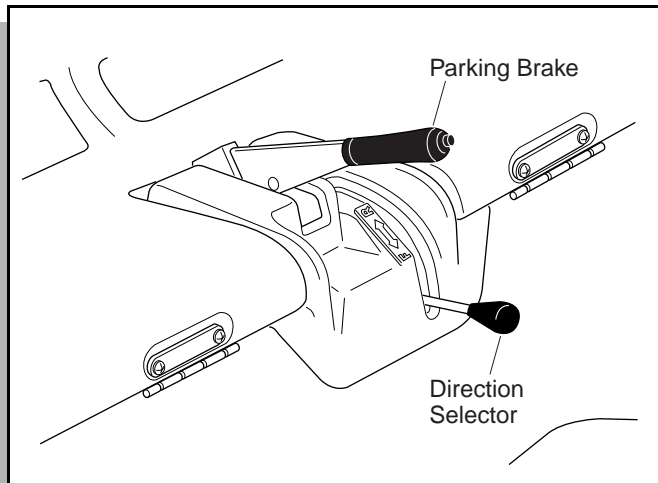

Fig. 9 Direction Selector and Parking Brake

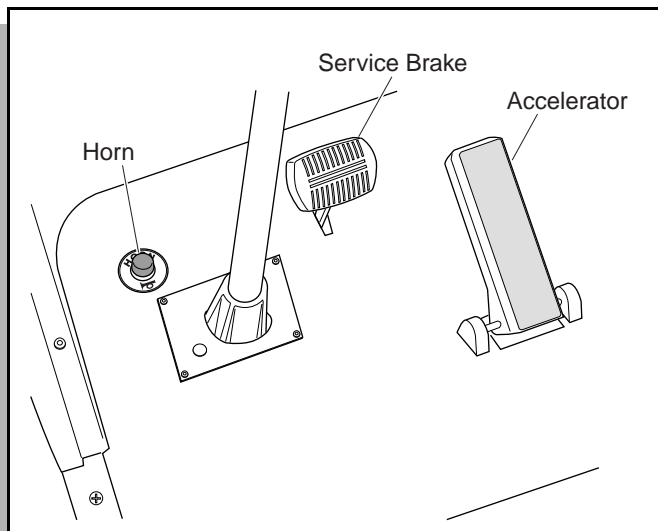

Fig. 10 Accelerator, Service Brake and Horn

Service Brake Pedal

Depressing the foot operated service brake pedal activates the wheel brakes, slowing or stopping the vehicle (Ref Fig. 10 on page 5).

Horn

The horn can be activated by depressing the button located on the floor to the left of the steering column (Ref Fig. 10 on page 5). The horn is located at the front of the vehicle underneath the cowl.

BEFORE ENTERING VEHICLE

1. Check for correct tire inflation.
2. Inspect for fluid leaks.

3. Be sure everything is properly stored and secured.

All vehicles are equipped with an interlock system that disables the controller and prevents the vehicle from being operated while the charger is connected. The interlock functions even if the DC plug is not fully connected in the vehicle receptacle. Remove charger plug from vehicle receptacle and properly store cable prior to moving vehicle. For on-board chargers, remove the AC cord from the dedicated outlet and store the cable in the cord storage compartment prior to moving the vehicle.

OPERATING THE VEHICLE

CAUTION Improper use of the vehicle or the lack of proper maintenance may result in decreased performance or damage to the vehicle.

NOTE Read and understand the following warnings before attempting to operate the vehicle.

WARNING Drive the vehicle only as fast as terrain and safety considerations allow.

Consider the terrain and traffic conditions. Also, consider the environmental factors which effect the terrain and the ability to control the vehicle.

Avoid driving fast down hill. A sudden stop or change of direction may result in loss of control. Use service brake to control speed when traveling down an incline.

Keep feet, legs, hands and arms inside the vehicle at all times.

Use extra care and reduced speed when driving on poor surfaces, such as loose dirt, wet grass, gravel, etc.

Stay in designated areas and avoid steep slopes. Use the parking brake whenever the vehicle is parked.

Avoid extremely rough terrain.

Check the area behind the vehicle before operating in reverse.

Make sure that the direction selector is in correct position before starting the vehicle.

Slow down before and during turns. All turns should be executed at reduced speed.

Always bring the vehicle to a complete stop before shifting the direction selector.

Always remain seated and hold on while the vehicle is in motion.

ELECTRIC CARGO AND PERSONNEL CARRIERS

Read all of manual to become thoroughly familiar with this vehicle. Pay particular attention to all Notes, Cautions and Warnings

Do not take vehicle out of gear while in motion (coast).

All travel should be directly up or down hills.

Use extra care when driving the vehicle across any incline.

When the vehicle is to be left unattended, engage the parking brake, place the direction selector in neutral position (the position between 'F' and 'R'), turn the key to the 'OFF' position and remove the key.

To start the electric vehicle: Apply the service brake, place the key in the key switch and turn to the 'ON' position. Move the direction selector to the direction desired, release the service brake pedal and depress the accelerator pedal to start the motor.

NOTE When the direction selector is in the reverse position, a warning signal will sound. This is a device to indicate the vehicle is ready to run in reverse.

The motor stops when the accelerator pedal is released. To stop the vehicle more quickly, depress the service brake pedal.

Starting the Vehicle on a Hill

CAUTION Do not hold vehicle on hill by using accelerator and motor. Leaving motor in a stalled condition for more than 3-4 seconds will cause permanent damage to motor.

When starting the vehicle on a hill, it is important to follow the procedure below to prevent excessive roll-back or permanent damage to the motor.

Place left foot on service brake and release the parking brake. Place right foot on accelerator pedal. As accelerator is depressed with the right foot, release the service brake by removing the left foot.

COASTING

On steep hills, it is possible for vehicles to coast at faster than normal speeds that may be encountered on a flat surface. To prevent loss of vehicle control, speeds should be limited to no more than the maximum speed on level ground (see vehicle specification). Limit speed by releasing the accelerator and applying service brake. Severe damage to the drive train components due to excessive speed may result from driving the vehicle above specified speed. Damage caused by excessive speed may cause a loss of control, is costly, is considered abuse and will not be covered under warranty.

SERVICING THE VEHICLE

WARNING Before attempting any type of servicing operations, read and understand all notes, cautions and warnings in this manual.

It is in the best interest of both vehicle owner and servicing dealer to carefully follow the procedures recommended in this manual. Adequate preventative maintenance, applied at regular intervals, is the best guarantee for keeping the E-Z-GO vehicle both dependable and economical.

WARNING To reduce the possibility of causing an electrical arc, which could result in a battery explosion, turn off all electrical loads from the batteries before removing any heavy gauge battery wires.



Wear eye protection when working on the vehicle. In particular, use care when working around the batteries, or when using solvents or compressed air.

Service requiring adjustments to be made to the powertrain while the motor is running must be made with both drive wheels raised.

Never operate vehicle at full throttle for more than 4-5 seconds while vehicle is in a "no load" condition.

Battery posts, terminals and related accessories contain lead and lead compounds. Wash hands after handling.

LIFTING THE VEHICLE

Some servicing operations may require the vehicle be raised. It is recommended this vehicle be lifted on one side or the other or the entire vehicle be lifted. Do not attempt to raise only the front end or rear end of the vehicle.

Tool List	Qty. Required
Floor jack	1
Jack stands.....	4
Chocks.....	4

WARNING To prevent possible injury or death, be sure the vehicle is on a firm and level surface. Never get under a vehicle while it is supported by a jack. Use jack stands and test the sta-

ELECTRIC CARGO AND PERSONNEL CARRIERS

Read all of manual to become thoroughly familiar with this vehicle. Pay particular attention to all Notes, Cautions and Warnings

bility of the vehicle on the stands. Always place chocks in front and behind the wheels not being raised. Use extreme care since the vehicle is extremely unstable during the lifting process.

Install chocks in front and behind each wheel not being raised. Place the jack under the frame directly behind the front wheel on the side to be lifted as indicated (Ref Fig. 11 on page 7). Raise the vehicle and locate a jack stand under the outer end of the rear axle. Place a jack stand under the outer end of the front axle.

Lower the jack and test the stability of the vehicle on the two jack stands.

If the entire vehicle is to be lifted, follow the same procedure at the other side of the vehicle.

Lower the jack and test the stability of the vehicle on the four jack stands.

Lower the vehicle by reversing the lifting sequence.

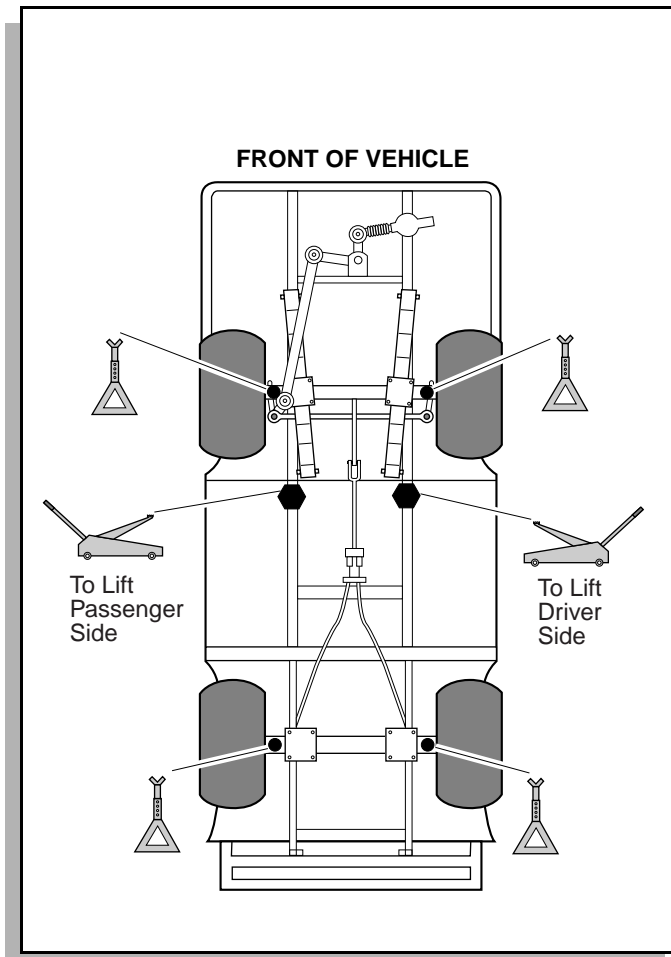

Fig. 11 Lifting the Vehicle

ROUTINE MAINTENANCE

This vehicle will give years of satisfactory service, providing it receives regular maintenance. Refer to the Periodic Service Schedule for appropriate service intervals (Ref Fig. 18 on page 13). Refer to Lubrication Points (Ref Fig. 12 on page 7) for appropriate lubrication locations.

NOTE Some maintenance items must be serviced more frequently on vehicles used under severe driving conditions.

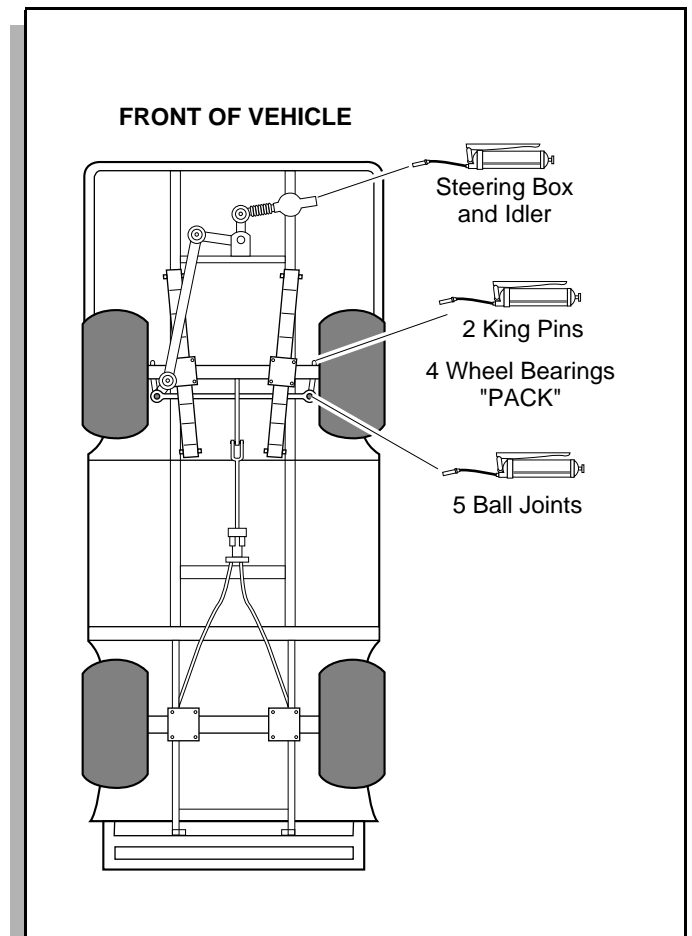

Fig. 12 Lubrication Points

REAR AXLE

The only maintenance required for the first five years is the periodic inspection of the lubricant level. The rear axle is provided with a lubricant level check/fill plug located on the bottom of the differential. Unless leakage is evident, the lubricant need only be replaced after five years.

ELECTRIC CARGO AND PERSONNEL CARRIERS

Read all of manual to become thoroughly familiar with this vehicle. Pay particular attention to all Notes, Cautions and Warnings

Checking the Lubricant Level

Clean the area around the check/fill plug and remove plug. The correct lubricant level is just below the bottom of the threaded hole. If lubricant is low, add as required. Add lubricant slowly until lubricant starts to seep from the hole. Install the check/fill plug. In the event that the lubricant is to be replaced, the vehicle must be elevated and the oil pan removed or the oil siphoned out through the check/fill hole (Ref Fig. 13 on page 8).

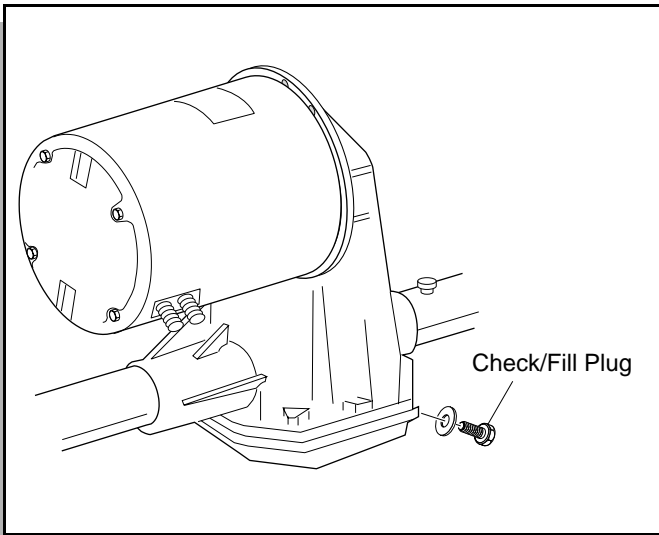

Fig. 13 Add, Check and Drain Rear Axle Lubricant

BRAKES

The fill cap for the master cylinder is located under the front seat. Loosen the screw and raise the seat. Remove the four screws securing the control panel and lift off panel to access master cylinder (Ref Fig. 14 on page 8).

It is important to maintain proper fluid levels in the brake master cylinder. When checking the fluid, wipe off any dirt from the fill cap before removing it to prevent contamination. Fluid level should be maintained at 1/8" (3 mm) below the top of the housing.

DAILY BRAKE TEST

After the vehicle has been put into service, it is recommended that the brakes be checked daily by performing the following test:



WARNING

All driving brake tests must be done in a safe location with regard for

the safety of all personnel.

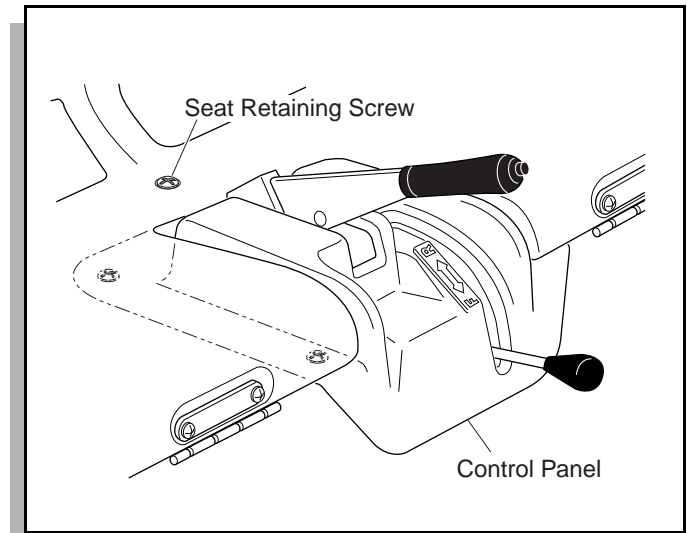

Fig. 14 Accessing Master Cylinder

Depress the brake pedal. The pedal should have some free travel and then become hard. A brake pedal that has no free travel, excessive free travel or a spongy feel is indicating that a brake inspection is required. A brake pedal that falls after it is applied indicates a leak in the master or wheel cylinders. Check for adequate brake fluid level. Adjust brakes if required and inspect system for fluid leaks.

TIRES

Tools List

Qty. Required

Lug wrench, 3/4"	1
Impact wrench, 1/2" drive	1
Impact socket, 3/4", 1/2" drive	1
Torque wrench, 1/2" drive, ft. lbs.	1

Tire condition should be inspected on a daily basis. Inflation pressures should be checked on a weekly basis when the tires are cool. Replace valve dust cap after checking or inflating tire.



Never exceed inflation pressure rating on tire sidewall.

Tire inflation should be determined by the condition of the terrain. See GENERAL SPECIFICATIONS section for recommended tire inflation pressure. For outdoor applications with major use on grassy areas, the following should be considered. On hard turf, it is desirable to have a **slightly** higher inflation pressure. On very soft turf, a lower pressure prevents tires from cutting into the turf.

ELECTRIC CARGO AND PERSONNEL CARRIERS

Read all of manual to become thoroughly familiar with this vehicle. Pay particular attention to all Notes, Cautions and Warnings

For vehicles being used on paved or hard surfaces, tire inflation pressure should be in the higher allowable range, but under no condition should inflation pressure be higher than recommended on tire sidewall. **All four tires** should have the same pressure for optimum handling characteristics. Be careful not to overinflate. Due to the low volume of these small tires, overinflation can occur in a matter of seconds. Be sure to install the valve dust cap after checking or inflating.

Tire Repair

⚠ WARNING ⚠ *To prevent injury caused by a broken socket, use only sockets designed for impact wrench use. Never use a conventional socket.*

The vehicle is fitted with low pressure tubeless tires mounted on one piece rims.

Generally, the most cost effective way to repair a flat tire resulting from a puncture in the tread portion of the tire is to use a commercial tire plug.

NOTE *Tire plug tools and plugs are available at most automotive parts outlets and have the advantage of not requiring the tire be removed from the wheel.*

If the tire is flat, remove the wheel and inflate the tire to the maximum recommended pressure for the tire. Immerse the tire in water to locate the leak and mark with chalk. Insert tire plug in accordance with manufacturer's specifications.

If the tire is to be removed or mounted, the tire changing machine manufacturer's recommendations must be followed in order to minimize the possibility of personal injury.

⚠ WARNING ⚠ *Pressurize tire with small amount of air applied intermittently to seat beads. Never exceed the tire manufacturer's recommendation.*

Protect face and eyes from escaping air when removing valve core.

Be sure mounting/demounting machine is anchored to floor.

Wear safety equipment when mounting/demounting tires.

Follow all instructions and safety warnings provided by the mounting/demounting machine manufacturer.

Wheel Installation

With the valve stem to the outside, mount the wheel onto the hub with lug nuts. Finger tighten lug nuts in a 'cross sequence' pattern. (Ref Fig. 15 on page 10) Then, tighten lug nuts to 50 - 85 ft. lbs. (70 - 115 Nm) torque in 20 ft. lbs. (30 Nm) increments following the same 'cross sequence' pattern.

ELECTRIC CARGO AND PERSONNEL CARRIERS

Read all of manual to become thoroughly familiar with this vehicle. Pay particular attention to all Notes, Cautions and Warnings

NOTE It is important to follow the 'cross sequence' pattern when installing lug nuts. This will assure even seating of the wheel against the hub.

CAUTION Do not tighten lug nuts to more than 85 ft. lbs. (115 Nm) torque.

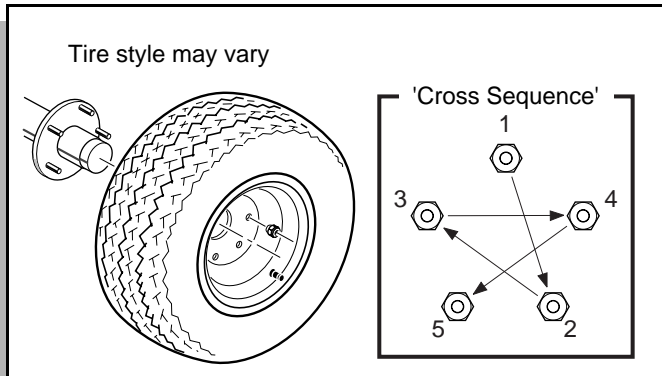

Fig. 15 Wheel Installation

LIGHT BULB REPLACEMENT

CAUTION To prevent premature bulb failure, do not touch new bulbs with bare fingers. Use a clean, dry tissue or paper towel to handle the glass portion of the bulb.

To replace a headlight, marker or turn signal bulb, remove access cover and remove bulb base with bulb from rear of light bar. Replace bulb and reinsert base into rear of light bar.

To replace the taillight bulb, roll the rubber bezel from around the edge of the taillight and remove lens. Replace with new bulb.

CARE AND CLEANING OF THE VEHICLE

CAUTION To prevent cosmetic damage, do not use any abrasive or reactive solvents to clean plastic parts.

It is important that proper techniques and cleaning materials be used.

Normal cleaning of vinyl seats and plastic or rubber trim requires the use of a mild soap solution applied with a sponge or soft brush and the subsequent removal of the material with a damp cloth.

Removal of oil, tar, asphalt, shoe polish, etc. will require the use of a commercially available vinyl/rubber cleaner.

The painted surfaces of the vehicle provide attractive appearance and durable protection. Frequent washing with lukewarm or cold water is the best method of preserving the painted surfaces.

Do not use hot water, strong soap or harsh chemical detergents.

Rubber parts should be cleaned with non-abrasive household cleaner.

Occasional cleaning and waxing with non-abrasive products designed for 'clear coat' automotive finishes will enhance the appearance and durability of the painted surfaces.

Corrosive materials used as fertilizers or for dust control can collect on the underbody of the vehicle. These materials will accelerate corrosion of underbody parts. It is recommended that the underbody be flushed occasionally with plain water. Thoroughly clean any areas where mud or other debris can collect. Sediment packed in closed areas should be loosened to ease its removal, taking care not to chip or otherwise damage paint.

TOP AND WINDSHIELD

WARNING *The top does not provide protection from roll over or falling objects.*

The windshield does not provide protection from tree limbs or flying objects.

Clean with lots of water and a clean cloth. Minor scratches may be removed using a commercial plastic polish or Plexus plastic cleaner available from E-Z-GO.

ELECTRIC CARGO AND PERSONNEL CARRIERS

Read all of manual to become thoroughly familiar with this vehicle. Pay particular attention to all Notes, Cautions and Warnings

TRAILERING



Personal injury to occupants of other highway vehicles may occur if vehicle and contents are not adequately secured to trailer.

Do not ride on vehicle being trailered.

Remove windshield before trailering. Maximum speed with top is 50 mph (80 kph).

If the vehicle is to be transported on a trailer at highway speeds, the windshield and top must be removed and the seat(s) secured. Always check that the vehicle and contents are adequately secured before trailering the vehicle. The rated capacity of the trailer must exceed the weight of the vehicle (see GENERAL SPECIFICATIONS section for vehicle weight) and load plus 1000 lbs. (454 kg). Lock the parking brake and secure the vehicle to the trailer using ratchet tie downs.

HARDWARE

Periodically, the vehicle should be inspected for loose fasteners. Fasteners should be tightened in accordance with the Torque Specifications table (Ref Fig. 18 on page 13). Use care when tightening fasteners and refer to the Technician's Repair and Service Manual for specific torque values.

Generally, two grades of hardware are used in the vehicle. Grade 5 hardware can be identified by the three marks on the hexagonal head. Unmarked hardware is Grade 2 (Ref Fig. 16 on page 11).

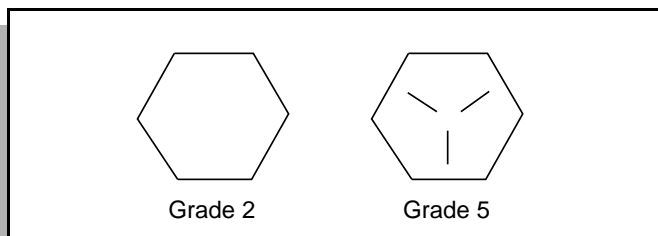

Fig. 16 Bolt Grades

ELECTRIC CARGO AND PERSONNEL CARRIERS

Read all of manual to become thoroughly familiar with this vehicle. Pay particular attention to all Notes, Cautions and Warnings

TORQUE SPECIFICATIONS

ALL TORQUE FIGURES ARE IN FT. LBS. (Nm)

Unless otherwise noted in text, tighten all hardware in accordance with this chart.
The table below specifies 'lubricated' torque figures. Fasteners that are plated or lubricated when installed are considered 'wet' and require approximately 80% of the torque required for 'dry' fasteners.

BOLT SIZE	1/4"	5/16"	3/8"	7/16"	1/2"	9/16"	5/8"	3/4"	7/8"	1"
Grade 2	4 (5)	8 (11)	15 (20)	24 (33)	35 (47)	55 (75)	75 (102)	130 (176)	125 (169)	190 (258)
Grade 5	6 (8)	13 (18)	23 (31)	35 (47)	55 (75)	80 (108)	110 (149)	200 (271)	320 (434)	480 (651)

Fig. 17 Torque Specifications

ELECTRIC CARGO AND PERSONNEL CARRIERS

Read all of manual to become thoroughly familiar with this vehicle. Pay particular attention to all Notes, Cautions and Warnings

PERIODIC SERVICE SCHEDULE

✓ Check	◆ Clean, Adjust, etc.	▲ Replace
NOTE: Some maintenance items must be serviced more frequently on vehicles used under severe driving conditions		
DAILY		
BODY	◆ Clean body components as required	
SERVICE BRAKE	✓ Check brake performance, smooth operation and adjust if required	
PARKING BRAKE	✓ Check brake performance and adjust if required	
REVERSE WARNING DEVICE	✓ Check operation when direction selector is in reverse	
TIRES	✓ Examine for cuts, excessive wear and pressure (See Specifications)	
WHEELS	✓ Check for bent rims, missing or loose lug nuts	
BATTERIES	◆ Recharge after each day's use	
CHARGER / RECEPTACLE	✓ Inspect connector system at each charge	
MONTHLY - 20 HOURS (includes items listed in previous tables & the following)		
BATTERIES	◆ Clean battery & terminals with 1/4 cup (60 ml) baking soda to 1 1/2 gallons (6 liters) water solution, rinse with clear water ✓ Check charge condition and all connections	
WIRING	✓ Check all wiring for loose connections and broken/missing insulation	
ACCELERATOR	✓ Check for smooth movement	
CHARGER / RECEPTACLE	◆ Clean connections, keep receptacles free of dirt and foreign matter	
DIRECTION SELECTOR	✓ Check attachment, tighten as required	
STEERING ASSEMBLY	✓ Check for abnormal play, tightness of all hardware	
TIE RODS/LINKAGES	✓ Check for excessive play, bent components or loose connections	
REAR AXLE	✓ Check for leakage, add SAE 30 oil as required	
QUARTERLY - 50 HOURS (includes items listed in previous tables & the following)		
FRONT AXLE	✓ Check for damage to axle and loose or missing hardware	
FRONT SHOCK ABSORBERS	✓ Check for oil leakage and loose fasteners	
FRONT SPRINGS	✓ Check for loose hardware, cracks at attachments	
FRONT WHEEL ALIGNMENT	✓ Check for unusual tire wear, align if required	
PARKING BRAKE	✓ Check for bent/binding linkage rod ✓ Check for damage or wear ◆ Lubricate, use light oil. DO NOT LUBRICATE CABLES	
HYDRAULIC BRAKE FLUID	✓ Check level, add if required and check for leakage (DOT 3)	
REAR SHOCK ABSORBERS	✓ Check for oil leakage, loose mounting hardware	

Fig. 18 Periodic Service Schedule



ELECTRIC CARGO AND PERSONNEL CARRIERS

Read all of manual to become thoroughly familiar with this vehicle. Pay particular attention to all Notes, Cautions and Warnings

SEMI-ANNUAL - 125 HOURS (includes items listed in previous tables & the following)	
DIRECTION SELECTOR	✓ Check for wear and smooth movement (lubricate shaft with light oil if required)
KING PINS	✓ Check for excessive play and tightness of retaining nuts ◆ Lubricate, use wheel bearing grease
STEERING ASSEMBLY	◆ Lubricate linkage, use wheel bearing grease
TIE RODS/LINKAGES	◆ Lubricate, use wheel bearing grease
REAR AXLE	✓ Check for unusual noise and mounting hardware
ANNUAL - 250-300 HOURS (includes items listed in previous tables & the following)	
FRONT WHEEL BEARINGS	◆ Adjust, see Technician's Repair and Service Manual ◆ Pack, use wheel bearing grease
REAR AXLE	✓ Check lubricant, add lubricant (SAE 30 oil) as required ▲ Replace lubricant after 500 hours or 5 years
SERVICE BRAKES	◆ Clean and adjust, see Technician's Repair and Service Manual ✓ Check brake shoe linings, see Technician's Repair and Service Manual

Fig. 18 Periodic Service Schedule

ELECTRIC CARGO AND PERSONNEL CARRIERS

Read all of manual to become thoroughly familiar with this vehicle. Pay particular attention to all Notes, Cautions and Warnings

BATTERIES AND CHARGING

Safety

NOTE Always observe the following warnings when working on or near batteries:

! WARNING ! Keep all smoking materials, open flame or sparks away from the batteries.

Hydrogen gas is formed when charging batteries. Do not charge batteries without adequate ventilation. A 4% concentration of hydrogen gas is explosive.

Be sure that the key switch is off and all electrical accessories are turned off before starting work on vehicle.

Never disconnect a circuit under load at a battery terminal.



Batteries are heavy. Use proper lifting techniques when moving them. Always lift the battery with a commercially available battery lifting device. Use care not to tip batteries when removing or installing them; spilled electrolyte can cause burns and damage.

The electrolyte in a storage battery is an acid solution which can cause severe burns to the skin and eyes. Treat all electrolyte spills to the body and eyes with extended flushing with clear water. Contact a physician immediately.

! WARNING ! Always wear a safety shield or approved safety goggles when adding water or charging batteries.

Any electrolyte spills should be neutralized with a solution of 1/4 cup (60 ml) sodium bicarbonate (baking soda) dissolved in 1 1/2 gallons (6 liters) of water and flushed with water.

Overfilling batteries may result in electrolyte being expelled from the battery during the charge cycle. Expelled electrolyte may cause damage to the vehicle and storage facility.

Aerosol containers of battery terminal protectant must be used with extreme care. Insulate the metal container to prevent the metal can from contacting battery terminals which could result in an explosion.

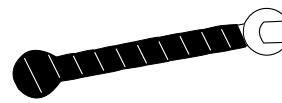

Wrap wrenches with vinyl tape to prevent the possibility of a dropped wrench from 'shorting out' a battery, which could result in an explosion and severe personal injury or death.

BATTERY

A battery is defined as two dissimilar metals immersed in an acid. If the acid is absent or if the metals are not dissimilar, a battery has not been created. The batteries most commonly used in these vehicles are lead acid.

A battery does not store electricity, but is able to produce electricity as the result of a chemical reaction which releases stored chemical energy in the form of electrical energy. The chemical reaction takes place faster in warm conditions and slower in cold conditions. Temperature is important when conducting tests on a battery and test results must be corrected to compensate for temperature differences.

As a battery ages, it still performs adequately except that its **capacity** is diminished. Capacity describes the time that a battery can continue to provide its design amperes from a full charge.

A battery has a maximum life, therefore good maintenance is designed to maximize the **available** life and reduce the factors that can reduce the life of the battery.

BATTERY MAINTENANCE

Tool List	Qty. Required
Insulated wrench, 1/2"	1
Battery carrier	1
Hydrometer	1
Battery maintenance kit P/N 25587-G01	1

At Each Charging Cycle

! WARNING ! Never attach a battery charger to a vehicle that is to be unattended beyond the normal charging cycle. Overcharging could cause damage to the vehicle batteries and result in extreme overheating. The charger should be checked after 24 hours and unplugged after the charge cycle is complete.

ELECTRIC CARGO AND PERSONNEL CARRIERS

Read all of manual to become thoroughly familiar with this vehicle. Pay particular attention to all Notes, Cautions and Warnings

Before charging the batteries, inspect the plug of the battery charger and vehicle receptacle housing for dirt or debris.

Charge the batteries after each days use.

Monthly

- Inspect all wiring for fraying, loose terminations, corrosion or deterioration of insulation.
- Check that the electrolyte level is correct and add suitable water as required.
- Clean the batteries and wire terminations.

Electrolyte Level and Water

The correct level of the electrolyte is 1/2" (13 mm) above the plates in each cell (Ref Fig. 19 on page 16).

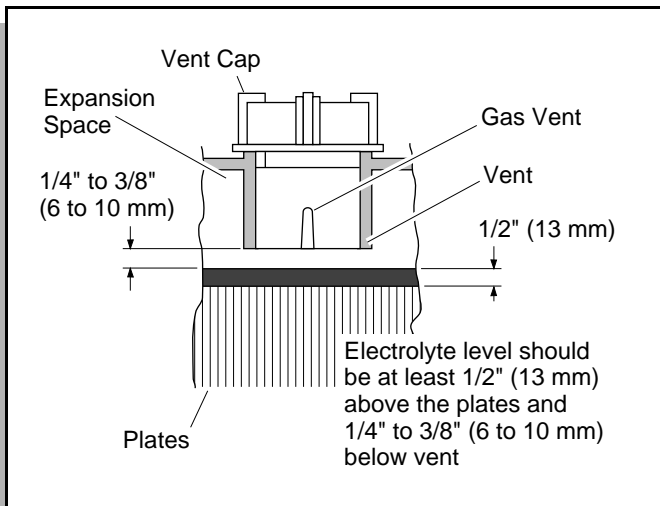

Fig. 19 Correct Electrolyte Level

This level will leave approximately 1/4" - 3/8" (6 - 10 mm) of space between the electrolyte and the vent tube. The electrolyte level is important since **any portion** of the plates exposed to air will be ruined beyond repair. Of equal importance is too much water which will result in electrolyte being forced out of the battery due to gassing and the increase in volume of the electrolyte that results from the charging cycle.

CAUTION Do not overfill batteries. The charging cycle will expel electrolyte and result in component damage.

Unless the electrolyte is at or below the plates, all watering should be done after charging.

A battery being charged will 'gas' with the majority of the gassing taking place at the end of the charging cycle.

This gas is hydrogen which is lighter than air. Water and sulfuric acid droplets will be carried out of the battery vents by the hydrogen gas; however, this loss is minimal. If the battery electrolyte level is too high, the electrolyte will block the vent tube and the gas will **force** it out of the vent tube and battery cap. The water will evaporate but the sulfuric acid will remain where it can damage vehicle components and the storage facility floor. Sulfuric acid loss will weaken the concentration of acid within the electrolyte and reduce the life of the battery.

Over the life of the battery, a considerable amount of water is consumed. It is important that the water used be pure and free of contaminants that could reduce the life of the battery by reducing the chemical reaction. The water must be distilled or purified by an efficient filtration system. Water that is not distilled should be analyzed and if required, filtration installed to permit the water to meet the requirements of the water purity table (Ref Fig. 20 on page 16).

Impurity	Parts Per Million
Color	Clear
Suspended	Trace
Total Solids	100
Calcium & Magnesium Oxides	40
Iron	5
Ammonia	8
Organic & Volatile Matter	50
Nitrites	5
Nitrates	10
Chloride	5

Fig. 20 Water Purity Table

Even if the water is colorless, odorless, tasteless and fit for drinking, the water should be analyzed to see that it does not exceed the impurity levels specified in the table.

Automatic watering devices such as the one included in the E-Z-GO Battery Maintenance Kit (P/N 25587-G01) can be used with an approved water source (Ref Fig. 21 on page 17). These watering devices are **fast and accurate** to use and maintain the correct electrolyte level within the battery cells.

NOTE The watering device should only be used if the electrolyte level is less than 1/2" (13 mm) above top of plates.

ELECTRIC CARGO AND PERSONNEL CARRIERS

Read all of manual to become thoroughly familiar with this vehicle. Pay particular attention to all Notes, Cautions and Warnings

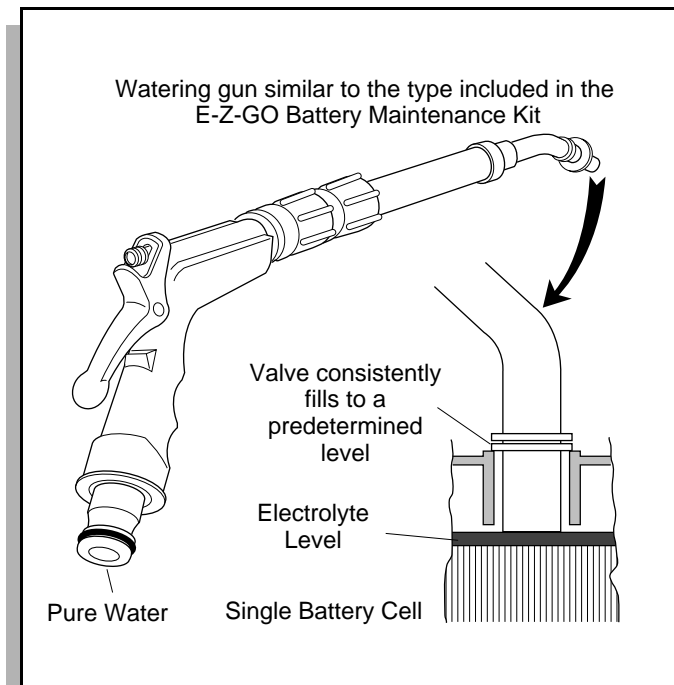

Fig. 21 Automatic Watering Gun

Cleaning Batteries

When cleaning the outside of the batteries and terminals, do not use a water hose without first spraying with a solution of sodium bicarbonate (baking soda) and water to neutralize any acid deposits.

Use of a water hose without first neutralizing any acid, will move acid from the top of the batteries to another area of the vehicle or storage facility where it will attack the metal structure or the concrete/asphalt floor. After hosing down the batteries, a residue will be left on the batteries which is conductive and will contribute to the discharge of the batteries.

CAUTION To prevent battery damage, be sure that all battery caps are tightly installed.

The correct cleaning technique is to spray the top and sides of the batteries with a solution of sodium bicarbonate (baking soda) and water. This solution is best applied with a garden type sprayer equipped with a **non metallic spray wand**. The solution should consist of 1/4 cup (60 ml) of sodium bicarbonate (baking soda) mixed with 1 1/2 gallons (6 liters) of clear water (Ref Fig. 22 on page 17). In addition to the batteries, special attention should be paid to metallic components adjacent to the batteries which should also be sprayed with the sodium bicarbonate (baking soda) solution.

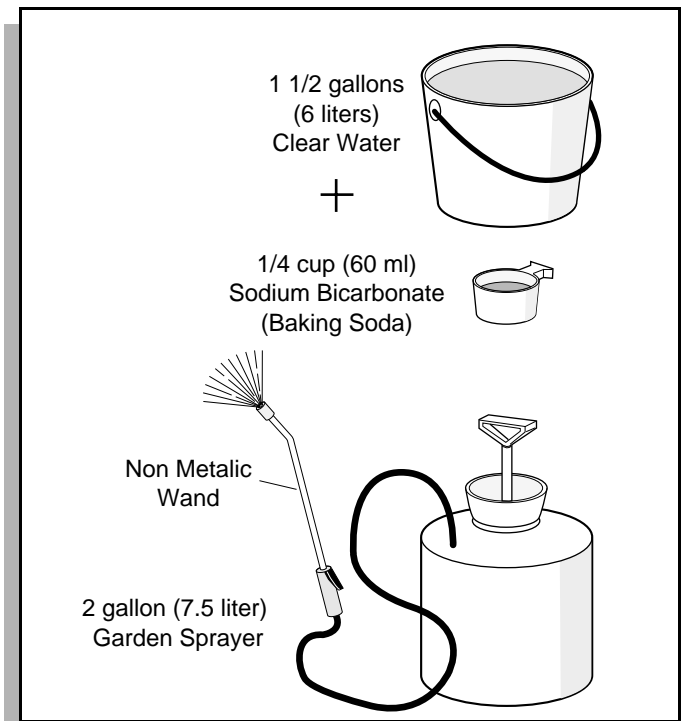

Fig. 22 Preparing Acid Neutralizing Solution

Allow the solution to sit for at least three minutes; use a soft bristle brush or cloth to wipe the tops of the batteries in order to remove any residue that could cause the self discharge of the battery. Rinse the entire area with low pressure clear water. All of the items required for complete battery cleaning and watering are contained in the E-Z-GO Battery Maintenance Kit (P/N 25587-G01).

Cleaning should take place once a month or more often under extreme conditions.

Battery Replacement

Remove battery hold downs and cables. Lift out batteries with a commercially available lifting device.

If the batteries have been cleaned and any acid in the battery rack area neutralized as recommended, no corrosion to the battery racks or surrounding area should be present. Any corrosion found should be immediately removed with a putty knife and a wire brush. The area should be washed with a solution of sodium bicarbonate (baking soda) and water and thoroughly dried before priming and painting with a corrosion resistant paint.

The batteries should be placed into the battery racks and the battery hold downs tightened to 45 - 55 in. lbs. (5 - 6 Nm) torque, to prevent movement but not tight enough to cause distortion of the battery cases.

ELECTRIC CARGO AND PERSONNEL CARRIERS

Read all of manual to become thoroughly familiar with this vehicle. Pay particular attention to all Notes, Cautions and Warnings

Inspect all wires and terminals. Clean any corrosion from the battery terminals or the wire terminals with a solution of sodium bicarbonate (baking soda) and brush clean if required.



Aerosol containers of battery terminal protectant must be used with extreme care. Insulate the metal container to prevent the metal can from contacting battery terminals which could result in an explosion.

Use care to connect the battery wires as shown (Ref Fig. 23 on page 18). Tighten the battery post hardware to 60 - 90 in. lbs. (7 - 10 Nm) torque. Protect the battery terminals and battery wire terminal with a commercially available coating.

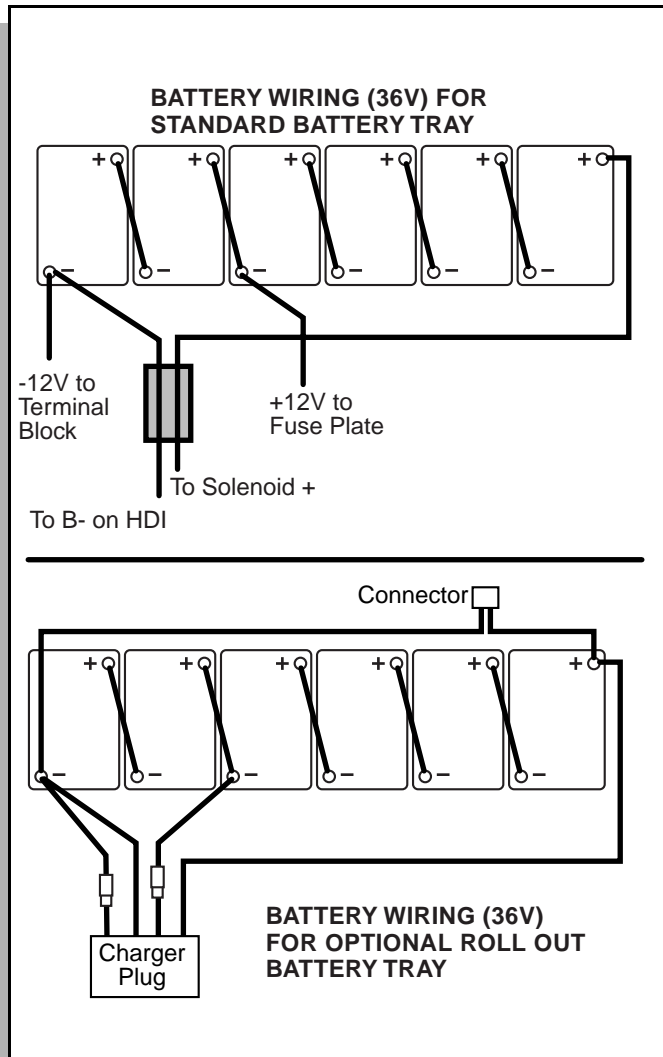

Fig. 23 Battery Connections (36V Systems)

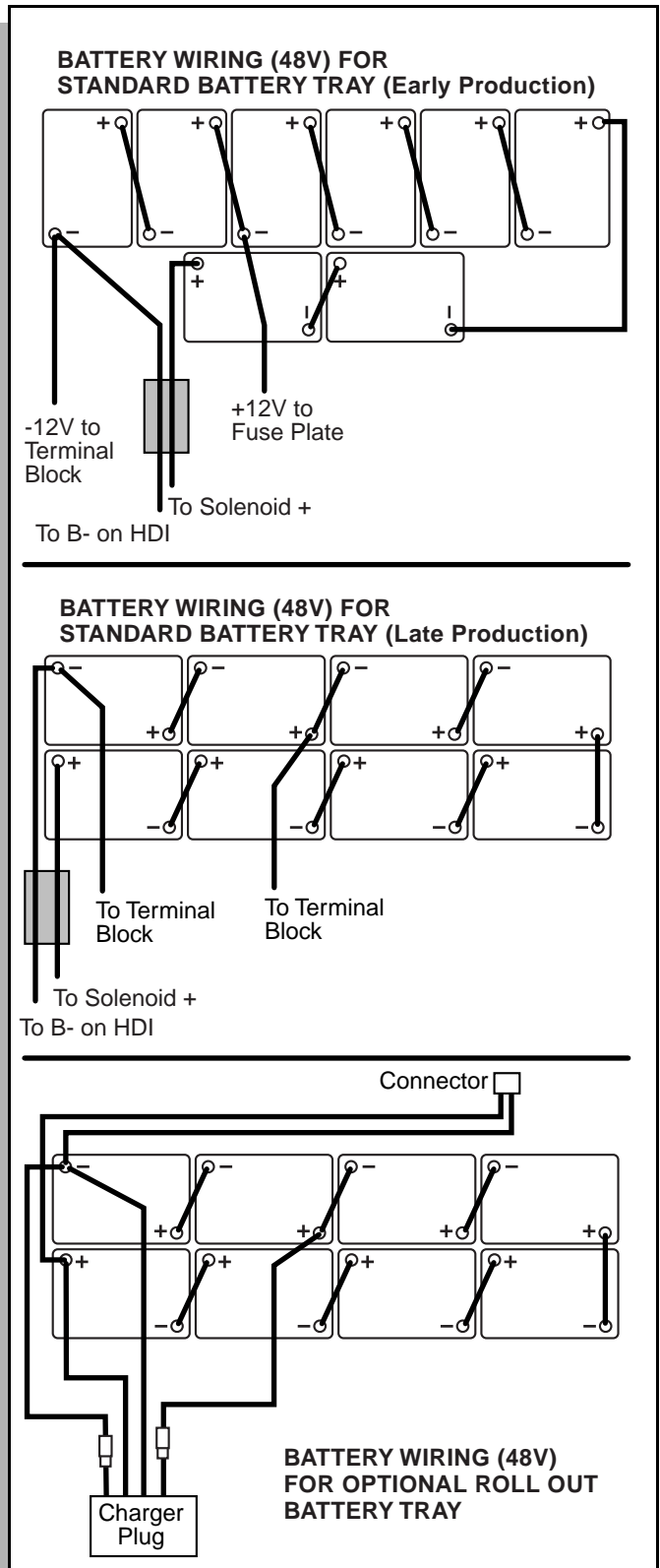

Fig. 24 Battery Connections (48V Systems)



ELECTRIC CARGO AND PERSONNEL CARRIERS

Read all of manual to become thoroughly familiar with this vehicle. Pay particular attention to all Notes, Cautions and Warnings

Prolonged Storage

CAUTION Battery charger and controller must be disconnected since they will contribute to the premature discharge of batteries. Other electronic devices may also need to be disconnected.

During periods of storage, the batteries will need attention to keep them maintained and prevent discharge.

In high temperatures the chemical reaction is faster, while low temperatures cause the chemical reaction to slow down. A vehicle that is stored at 90° F (32° C) will lose .002 of specific gravity each day. If a fully charged battery has a specific gravity of 1.275, and the battery is allowed to sit unused, it will become partially discharged. When it reaches 1.240, which it will do in less than twenty days, it should be recharged. If a battery is left in a discharged state, sulfating takes place on and within the plates. This condition is not reversible and will cause permanent damage to the battery. In order to prevent damage, the battery should be recharged. A hydrometer (E-Z-GO P/N 50900-G1) can be used to determine the specific gravity and therefore the state of charge of a battery.

In winter conditions, the battery must be fully charged to prevent the possibility of freezing (Ref Fig. 25 on page 19). A fully charged battery will not freeze in temperatures above -75° F (-60° C). Although the chemical reaction is slowed in cold temperatures, the battery must be stored fully charged, and disconnected from any circuit that could discharge the battery. For portable chargers, disconnect the charging plug from the vehicle receptacle. For on-board chargers, disconnect the charging harness from the batteries. The batteries must be cleaned and all deposits neutralized and removed from the battery case to prevent self discharge. The batteries should be tested or recharged at thirty day minimum intervals.

Battery Charging

The battery charger is designed to fully charge the battery set. If the batteries are severely deep cycled, some automatic battery chargers contain an electronic module that may not activate and the battery charger will not function. Automatic chargers will determine the correct duration of charge to the battery set and will shut off when the battery set is fully charged. Always refer to the instructions of the specific charger used.

Before charging, the following should be observed:

CAUTION Do not overfill batteries. The charging cycle will expel electrolyte and result in component damage.

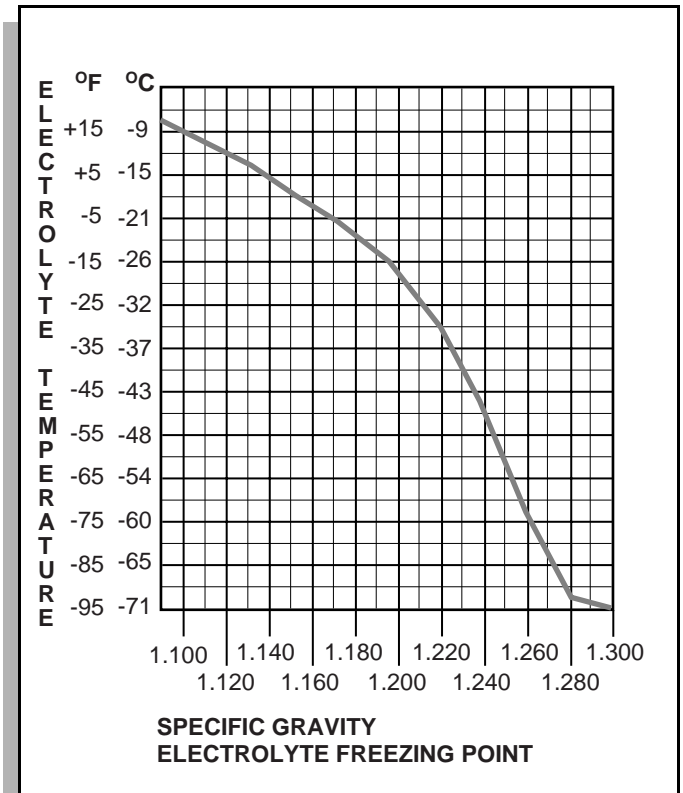

Fig. 25 Freezing Point of Electrolyte

- The electrolyte level in all cells must be at the recommended level and cover the plates.
- The charging must take place in an area that is well ventilated and capable of removing the hydrogen as that is generated by the charging process. A **minimum** of five air exchanges per hour is recommended.
- The charging connector components are in good condition and free from dirt or debris.
- The charger connector is fully inserted into the vehicle receptacle.
- The charger connector/cord set is protected from damage and is located in an area to prevent injury that may result from personnel running over or tripping over the cord set.
- The charger is automatically turned off during the connect/disconnect cycle and therefore no electrical arc is generated at the DC plug/receptacle contacts.

NOTE In some portable chargers, there will be a rattle present in the body of the charger DC plug. This rattle is caused by an internal magnet contained within the

ELECTRIC CARGO AND PERSONNEL CARRIERS

Read all of manual to become thoroughly familiar with this vehicle. Pay particular attention to all Notes, Cautions and Warnings

charger plug. The magnet is part of the interlock system that prevents the vehicle from being driven when the charger plug is inserted in the vehicle charging receptacle.

AC Voltage

Battery charger output is directly related to the input voltage. If multiple vehicles are receiving an incomplete charge in a normally adequate time period, low AC voltage could be the cause and the power company should be consulted.

TROUBLESHOOTING

In general, troubleshooting will be done for two distinct reasons. First, a battery that performs poorly and is outside of the manufacturer's specification should be identified in order to replace it under the terms of the manufacturer's warranty. Different manufacturers have different requirements. Consult the battery manufacturer or an E-Z-GO representative for specific requirements.

The second reason is to determine why a particular vehicle does not perform adequately. Performance problems may result in a vehicle that runs slowly or in a vehicle that is unable to operate for the time required.

A new battery must **mature** before it will develop its maximum capacity. Maturing may take up to 100 charge/discharge cycles. After the maturing phase, the older a battery gets, the lower the capacity. The only way to determine the capacity of a battery is to perform a load test using a discharge machine.

A cost effective way to identify a poorly performing battery is to use a hydrometer to identify a battery in a set with a lower than normal specific gravity. Once the particular cell or cells that are the problem are identified, the suspect battery can be removed and replaced. At this point there is nothing that can be done to salvage the battery; however, the individual battery should be replaced with a good battery of the same brand, type and approximate age.

Hydrometer

A hydrometer (E-Z-GO P/N 50900-G1) is used to test the state of charge of a battery cell (Ref Fig. 26 on page 20). This is performed by measuring the density of the electrolyte, which is accomplished by measuring the specific gravity of the electrolyte. The greater the concentration of sulfuric acid, the more dense the electrolyte becomes. The higher the density, the higher the state of charge.

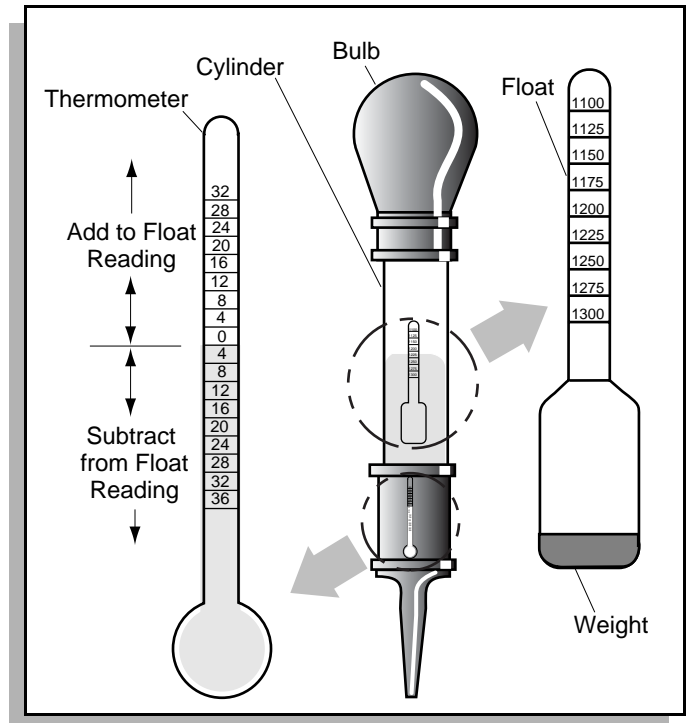

Fig. 26 Hydrometer



WARNING To prevent a battery explosion, never insert a metal thermometer into a battery. Use a hydrometer with a built in thermometer that is designed for testing batteries.

Specific gravity is the measurement of a liquid that is compared to a baseline. The baseline is water which is assigned a base number of 1.000. The concentration of sulfuric acid to water in a new golf car battery is 1.280 which means that the electrolyte weighs 1.280 times the weight of the same volume of water. A fully charged battery will test at 1.275 - 1.280 while a discharged battery will read in the 1.140 range.



NOTE Do not perform a hydrometer test on a battery that has just been watered. The battery must go through at least one charge and discharge cycle in order to permit the water to adequately mix with the electrolyte.

The temperature of the **electrolyte** is important since the hydrometer reading must be corrected to 80° F (27° C). High quality hydrometers are equipped with an internal thermometer that will measure the temperature of the electrolyte and will include a conversion scale to correct the float reading. It is important to recognize that the electrolyte temperature is significantly different from the ambient temperature if the vehicle has been operated.

ELECTRIC CARGO AND PERSONNEL CARRIERS

Read all of manual to become thoroughly familiar with this vehicle. Pay particular attention to all Notes, Cautions and Warnings

Using A Hydrometer

1. Draw electrolyte into the hydrometer several times to permit the thermometer to adjust to the electrolyte temperature and note the reading. Examine the color of the electrolyte. A brown or gray coloration indicates a problem with the battery and is a sign that the battery is nearing the end of its life.
2. Draw the minimum quantity of electrolyte into the hydrometer to permit the float to float freely without contacting the top or bottom of the cylinder.
3. Hold the hydrometer in a vertical position at eye level and note the reading where the electrolyte meets the scale on the float.
4. Add or subtract four points (.004) to the reading for every 10°F (6°C) the electrolyte temperature is above or below 80° F (27° C). Adjust the reading to conform with the electrolyte temperature, e.g., if the reading indicates a specific gravity of 1.250 and the electrolyte temperature is 90° F (32° C), **add** four points (.004) to the 1.250 which gives a corrected reading of 1.254. Similarly if the temperature was 70° F (21°C), **subtract** four points (.004) from the 1.250 to give a corrected reading of 1.246 (Ref Fig. 27 on page 21).
5. Test each cell and note the readings (corrected to 80° F or 27° C). A variation of fifty points between any two cell readings (example 1.250 - 1.200) indicates a problem with the low reading cell(s).

As a battery ages the specific gravity of the electrolyte will decrease at full charge. This is not a reason to replace the battery, providing all cells are within fifty points of each other.

Since the hydrometer test is in response to a vehicle exhibiting a performance problem, the vehicle should be recharged and the test repeated. If the results indicate a weak cell, the battery or batteries should be removed and replaced with a good battery of the same brand, type and approximate age.

BATTERY CHARGER MAINTENANCE

The only maintenance required of the charger is the periodic cleaning of the DC connector auxiliary contact.

To clean the auxiliary contact, slide an emery board between main contact and auxiliary contact located in the hole of the charger plug nearest the rounded corners (Ref Fig. 28 on page 21). Press emery board down to apply pressure to the auxiliary contact and slide board in and out of plug approximately 10 to 20 times, keeping pressure applied to the auxiliary contact surface.

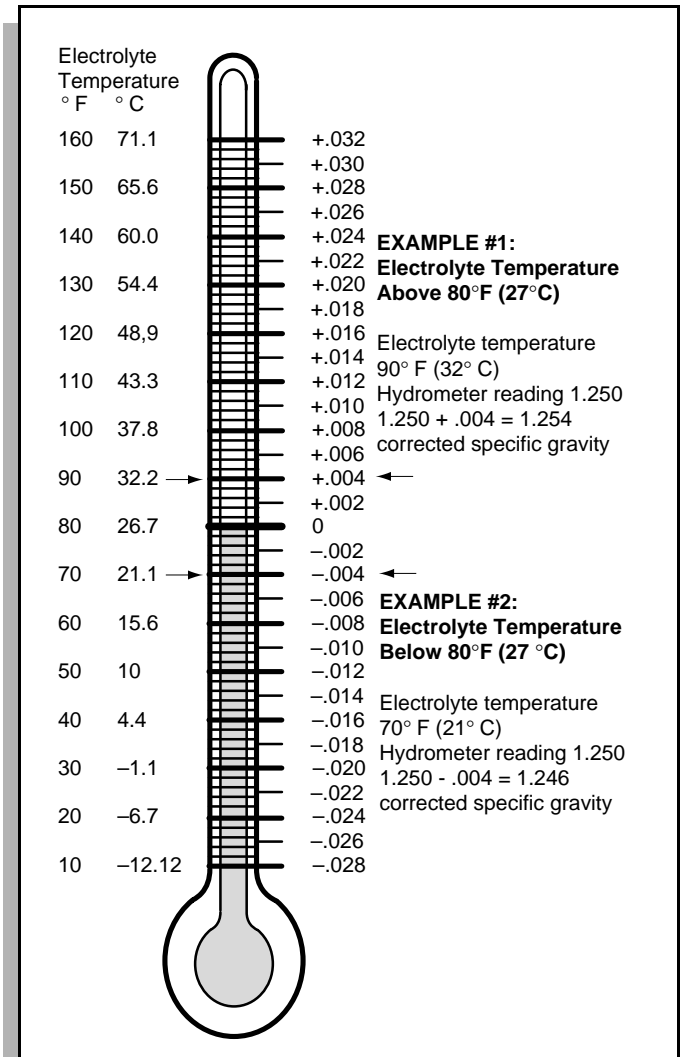

Fig. 27 Hydrometer Temperature Correction

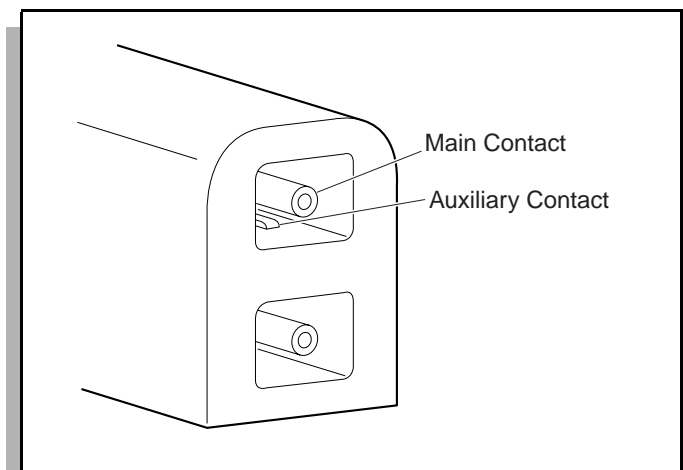

Fig. 28 Cleaning Auxiliary Contact in Charger Plug

ELECTRIC CARGO AND PERSONNEL CARRIERS

Read all of manual to become thoroughly familiar with this vehicle. Pay particular attention to all Notes, Cautions and Warnings



GENERAL SPECIFICATIONS

GENERAL SPECIFICATIONS

SHUTTLE 952E

2 Passenger Personnel/Cargo Carrier

WEIGHT (without batteries)	840 lbs. (381 kg)
HEIGHT (at top of sun top)	76 in. (193 cm)
GROUND CLEARANCE (at differential)	5.0 in. (13 cm)
TIRES	5.70 x 8 (6 ply rated)
TIRE PRESSURE	50 psi (344 kPa)
LOAD CAPACITY (including operator, passenger, cargo and accessories)	2,000 lbs. (907 kg)
CHASSIS	Welded high yield strength tubular steel with powder coat paint
BODY & FINISH.....	Molded fiberglass reinforced plastic
BODY PROTECTION	Wrap around bumper and protective side molding
SAFETY	Removable switch key, electric horn, brake lights, handgrip and hip restraints, reverse warning indicator, "deadman" accelerator control, manual Forward and Reverse switch with "neutral"
LIGHTING PACKAGE	Single light bar assembly, taillights and brake lights
FEATURES	State of charge meter
STEERING WHEEL.....	Pencil holder integrated in clipboard
BRAKES	Dual rear wheel, hydraulic drum brakes. Hand operated parking brake
CARGO DECK.....	Hinged deck for access to drive train and rear storage area
FRONT SUSPENSION	Heavy duty multiple leaf springs with hydraulic shock absorbers
REAR SUSPENSION.....	Heavy duty multiple leaf springs with hydraulic shock absorbers
STEERING.....	Self-compensating double reduction rack and pinion
SEATING.....	One molded one piece seat. Seating for two occupants. Seat tilts for access to steering linkage and master cylinder
SPEED	12 - 14 mph (19 - 22 kph)
TRANSAXLE.....	High efficiency differential with helical gears, 14.78:1 ratio
CLASSIFICATION.....	UL (Underwriters Laboratory) Approved type "E" classification

36 VOLT VEHICLE:

ELECTRICAL SYSTEM	36 volt DC, six 6 volt heavy duty, deep cycle storage batteries (107 minute, 220 amp hour @ 20 hour discharge rate)
SPEED CONTROL	Solid state controller, 400 amp rated
MOTOR.....	36 volt DC, high efficiency series wound, brazed armature, solid copper windings, vented, 2 hp at 2800 rpm, 3 hp at 2350 rpm
CHARGER	PowerWise™ on board or portable fully automatic, 21 amp DC output at 36 volts; input 110 - 120 volts, 9.5 amps, 60 cycle AC, Underwriters Laboratory (UL) Listed, CSA Certified, anti-drive away charger/vehicle interlock

48 VOLT VEHICLE:

ELECTRICAL SYSTEM	48 volt DC, eight 6 volt heavy duty deep cycle batteries (107 minute, 220 amp hour @ 20 hour discharge rate)
SPEED CONTROL	Solid State HDI Controller, 350 amp rated
MOTOR.....	Heavy duty, 48 volt DC, high efficiency series wound, brazed armature, solid copper windings, vented, 5.5 hp (4.0 kw) at 1980 rpm
CHARGER	On board or portable fully automatic, 21 amp DC output at 48 volts; input 110 - 120 volts, 12.2 amps, 60 cycle AC, Underwriters Laboratory (UL) Listed, CSA Certified, anti-drive away charger/vehicle interlock

Specifications subject to change without notice.



GENERAL SPECIFICATIONS

SHUTTLE 954E

5 Passenger Personnel/Cargo Carrier

WEIGHT (without batteries)	840 lbs. (381 kg)
HEIGHT (at top of sun top)	76 in. (193 cm)
GROUND CLEARANCE (at differential)	5.0 in. (13 cm)
TIRES	5.70 x 8 (6 ply rated)
TIRE PRESSURE	50 psi (344 kPa)
LOAD CAPACITY (including operator, passenger, cargo and accessories)	2,000 lbs. (907 kg)
CHASSIS	Welded high yield strength tubular steel with powder coat paint
BODY & FINISH	Molded fiberglass reinforced plastic
BODY PROTECTION	Wrap around bumper and protective side molding
SAFETY	Removable switch key, electric horn, brake lights, handgrip and hip restraints, reverse warning indicator, "deadman" accelerator control, manual Forward and Reverse switch with "neutral"
LIGHTING PACKAGE	Single light bar assembly, taillights and brake lights
FEATURES	State of charge meter
STEERING WHEEL	Pencil holder integrated in clipboard
BRAKES	Dual rear wheel, hydraulic drum brakes. Hand operated parking brake
CARGO DECK	Hinged deck for access to drive train and rear storage area
FRONT SUSPENSION	Heavy duty multiple leaf springs with hydraulic shock absorbers
REAR SUSPENSION	Heavy duty multiple leaf springs with hydraulic shock absorbers
STEERING	Self-compensating double reduction rack and pinion
SEATING	Two molded one piece seats. Seating for five occupants. Seats tilt for access to steering linkage, master cylinder and drive train
SPEED	12 - 14 mph (19 - 22 kph)
TRANSAXLE	High efficiency differential with helical gears, 14.78:1 ratio
CLASSIFICATION	UL (Underwriters Laboratory) Approved type "E" classification
36 VOLT VEHICLE:	
ELECTRICAL SYSTEM	36 volt DC, six 6 volt heavy duty, deep cycle storage batteries (107 minute, 220 amp hour @ 20 hour discharge rate)
SPEED CONTROL	Solid state controller, 400 amp rated
MOTOR	36 volt DC, high efficiency series wound, brazed armature, solid copper windings, vented, 2 hp at 2800 rpm, 3 hp at 2350 rpm
CHARGER	PowerWise™ on board or portable fully automatic, 21 amp DC output at 36 volts; input 110 - 120 volts, 9.5 amps, 60 cycle AC, Underwriters Laboratory (UL) Listed, CSA Certified, anti-drive away charger/vehicle interlock
48 VOLT VEHICLE:	
ELECTRICAL SYSTEM	48 volt DC, eight 6 volt heavy duty deep cycle batteries (107 minute, 220 amp hour @ 20 hour discharge rate)
SPEED CONTROL	Solid State HDI Controller, 350 amp rated
MOTOR	Heavy duty, 48 volt DC, high efficiency series wound, brazed armature, solid copper windings, vented, 5.5 hp (4.0 kw) at 1980 rpm
CHARGER	On board or portable fully automatic, 21 amp DC output at 48 volts; input 110 - 120 volts, 12.2 amps, 60 cycle AC, Underwriters Laboratory (UL) Listed, CSA Certified, anti-drive away charger/vehicle interlock

Specifications subject to change without notice.



GENERAL SPECIFICATIONS

SHUTTLE 955E 8 Passenger Personnel/Cargo Carrier

WEIGHT (without batteries)	1020 lbs. (463 kg)
HEIGHT (at top of sun top)	76 in. (193 cm)
GROUND CLEARANCE (at differential)	5.0 in. (13 cm)
TIRES	5.70 x 8 (6 ply rated)
TIRE PRESSURE	50 psi (344 kPa)
LOAD CAPACITY (including operator, passenger, cargo and accessories)	2,500 lbs. (1134 kg)
CHASSIS	Welded high yield strength tubular steel with powder coat paint
BODY & FINISH.....	Molded fiberglass reinforced plastic
BODY PROTECTION	Wrap around bumper and protective side molding
SAFETY	Removable switch key, electric horn, brake lights, handgrip and hip restraints, reverse warning indicator, "deadman" accelerator control, manual Forward and Reverse switch with "neutral"
LIGHTING PACKAGE	Single light bar assembly, taillights and brake lights
FEATURES	State of charge meter
STEERING WHEEL.....	Pencil holder integrated in clipboard
BRAKES	Dual rear wheel, hydraulic drum brakes. Hand operated parking brake
CARGO DECK.....	Hinged deck for access to drive train and rear storage area
FRONT SUSPENSION	Heavy duty multiple leaf springs with hydraulic shock absorbers
REAR SUSPENSION.....	Heavy duty multiple leaf springs with hydraulic shock absorbers
STEERING.....	Self-compensating double reduction rack and pinion
SEATING.....	Three molded one piece seats. Seating for eight occupants. Seat tilts for access to steering linkage and master cylinder
SPEED	12 - 14 mph (19 - 22 kph)
ELECTRICAL SYSTEM	48 volt DC, eight 6 volt heavy duty, deep cycle storage batteries(107 minute, 220 amp hour @ 20 hour discharge rate)
SPEED CONTROL	Solid State HDI Controller, 350 amp rated
MOTOR.....	Heavy duty 48 volt high efficiency series wound, brazed armature, solid copper windings, vented 5.5 hp (4.0 kw) at 1980 rpm
DRIVE TRAIN	Direct motor shaft connected to transaxle pinion shaft
TRANSAXLE.....	High efficiency differential with helical gears, 14.78:1 ratio
CHARGER	On board or portable fully automatic, 21 amp DC output at 48 volts; input 110 - 120 volts, 12.6 amps, 60 cycle AC, Underwriters Laboratory (UL) Listed, CSA Certified, anti-drive away charger/vehicle interlock
CLASSIFICATION.....	UL (Underwriters Laboratory) Approved type "E" classification

Specifications subject to change without notice.



GENERAL SPECIFICATIONS

SHUTTLE 956E 8 Passenger Personnel Carrier

WEIGHT (without batteries)	840 lbs. (381 kg)
HEIGHT (at top of sun top)	76 in. (193 cm)
GROUND CLEARANCE (at differential)	5.0 in. (13 cm)
TIRES	5.70 x 8 (6 ply rated)
TIRE PRESSURE	50 psi (344 kPa)
LOAD CAPACITY (including operator, passenger, cargo and accessories)	2,000 lbs. (907 kg)
CHASSIS	Welded high yield strength tubular steel with powder coat paint
BODY & FINISH	Molded fiberglass reinforced plastic
BODY PROTECTION	Wrap around bumper and protective side molding
SAFETY	Removable switch key, electric horn, brake lights, handgrip and hip restraints, reverse warning indicator, "deadman" accelerator control, manual Forward and Reverse switch with "neutral"
LIGHTING PACKAGE	Single light bar assembly, taillights and brake lights
FEATURES	State of charge meter
STEERING WHEEL	Pencil holder integrated in clipboard
BRAKES	Dual rear wheel, hydraulic drum brakes. Hand operated parking brake
FRONT SUSPENSION	Heavy duty multiple leaf springs with hydraulic shock absorbers
REAR SUSPENSION	Heavy duty multiple leaf springs with hydraulic shock absorbers
STEERING	Self-compensating double reduction rack and pinion
SEATING	Three molded one piece seats. Seating for eight occupants. Seats tilt for access to steering linkage, master cylinder and drive train
SPEED	12 - 14 mph (19 - 22 kph)
TRANSAXLE	High efficiency differential with helical gears, 14.78:1 ratio
CLASSIFICATION	UL (Underwriters Laboratory) Approved type "E" classification
36 VOLT VEHICLE:	
ELECTRICAL SYSTEM	36 volt DC, six 6 volt heavy duty, deep cycle storage batteries (107 minute, 220 amp hour @ 20 hour discharge rate)
SPEED CONTROL	Solid state controller, 400 amp rated
MOTOR	36 volt DC, high efficiency series wound, brazed armature, solid copper windings, vented, 2 hp at 2800 rpm, 3 hp at 2350 rpm
CHARGER	PowerWise™ on board or portable fully automatic, 21 amp DC output at 36 volts; input 110 - 120 volts, 9.5 amps, 60 cycle AC, Underwriters Laboratory (UL) Listed, CSA Certified, anti-drive away charger/vehicle interlock
48 VOLT VEHICLE:	
ELECTRICAL SYSTEM	48 volt DC, eight 6 volt heavy duty deep cycle batteries (107 minute, 220 amp hour @ 20 hour discharge rate)
SPEED CONTROL	Solid State HDI Controller, 350 amp rated
MOTOR	Heavy duty, 48 volt DC, high efficiency series wound, brazed armature, solid copper windings, vented, 5.5 hp (4.0 kw) at 1980 rpm
CHARGER	On board or portable fully automatic, 21 amp DC output at 48 volts; input 110 - 120 volts, 12.2 amps, 60 cycle AC, Underwriters Laboratory (UL) Listed, CSA Certified, anti-drive away charger/vehicle interlock

Specifications subject to change without notice.



GENERAL SPECIFICATIONS

SHUTTLE 957E

11 Passenger Personnel Carrier

WEIGHT (without batteries)	1020 lbs. (463 kg)
HEIGHT (at top of sun top)	76 in. (193 cm)
GROUND CLEARANCE (at differential)	5.0 in. (13 cm)
TIRES	5.70 x 8 (6 ply rated)
TIRE PRESSURE	50 psi (344 kPa)
LOAD CAPACITY (including operator, passenger, cargo and accessories)	2,500 lbs. (1134 kg)
CHASSIS	Welded high yield strength tubular steel with powder coat paint
BODY & FINISH.....	Molded fiberglass reinforced plastic
BODY PROTECTION	Wrap around bumper and protective side molding
SAFETY	Removable switch key, electric horn, brake lights, handgrip and hip restraints, reverse warning indicator, "deadman" accelerator control, manual Forward and Reverse switch with "neutral"
LIGHTING PACKAGE	Single light bar assembly, taillights and brake lights
FEATURES	State of charge meter
STEERING WHEEL.....	Pencil holder integrated in clipboard
BRAKES	Dual rear wheel, hydraulic drum brakes. Hand operated parking brake
CARGO DECK.....	Hinged deck for access to drive train and rear storage area
FRONT SUSPENSION	Heavy duty multiple leaf springs with hydraulic shock absorbers
REAR SUSPENSION.....	Heavy duty multiple leaf springs with hydraulic shock absorbers
STEERING.....	Self-compensating double reduction rack and pinion
SEATING.....	Four molded one piece seats. Seating for eleven occupants. Seats tilt for access to steering linkage, master cylinder and drive train
SPEED	12 - 14 mph (19 - 22 kph)
ELECTRICAL SYSTEM	48 volt DC, eight 6 volt heavy duty, deep cycle storage batteries(107 minute, 220 amp hour @ 20 hour discharge rate)
SPEED CONTROL	Solid State HDI Controller, 350 amp rated
MOTOR.....	Heavy duty 48 volt high efficiency series wound, brazed armature, solid copper windings, vented 5.5 hp (4.0 kw) at 1980 rpm
DRIVE TRAIN	Direct motor shaft connected to transaxle pinion shaft
TRANSAXLE.....	High efficiency differential with helical gears, 14.78:1 ratio
CHARGER	On board or portable fully automatic, 21 amp DC output at 48 volts; input 110 - 120 volts, 12.6 amps, 60 cycle AC, Underwriters Laboratory (UL) Listed, CSA Certified, anti-drive away charger/vehicle interlock
CLASSIFICATION.....	UL (Underwriters Laboratory) Approved type "E" classification

Specifications subject to change without notice.



GENERAL SPECIFICATIONS

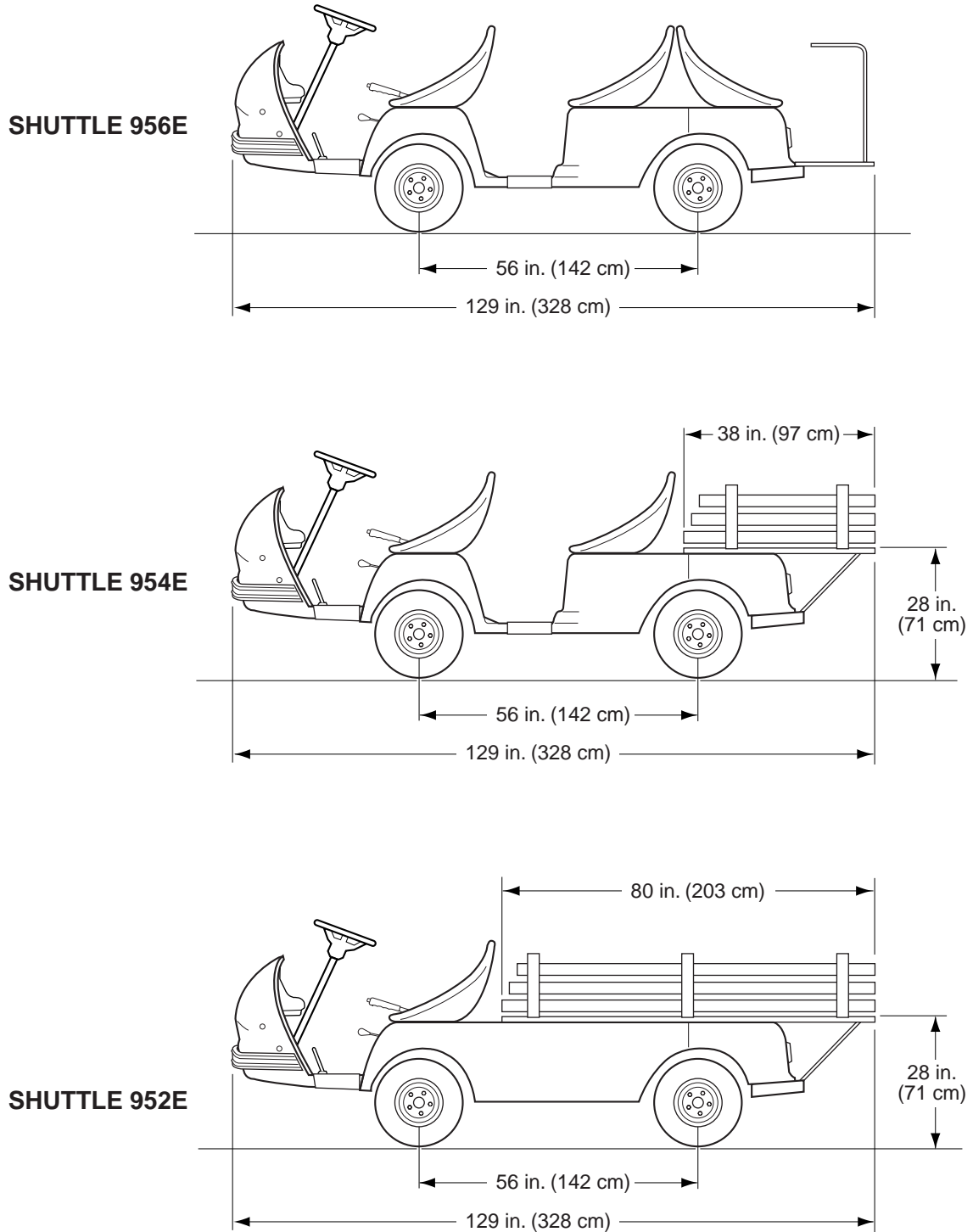

Fig. 29 952, 954 and 956 Vehicle Dimensions

GENERAL SPECIFICATIONS

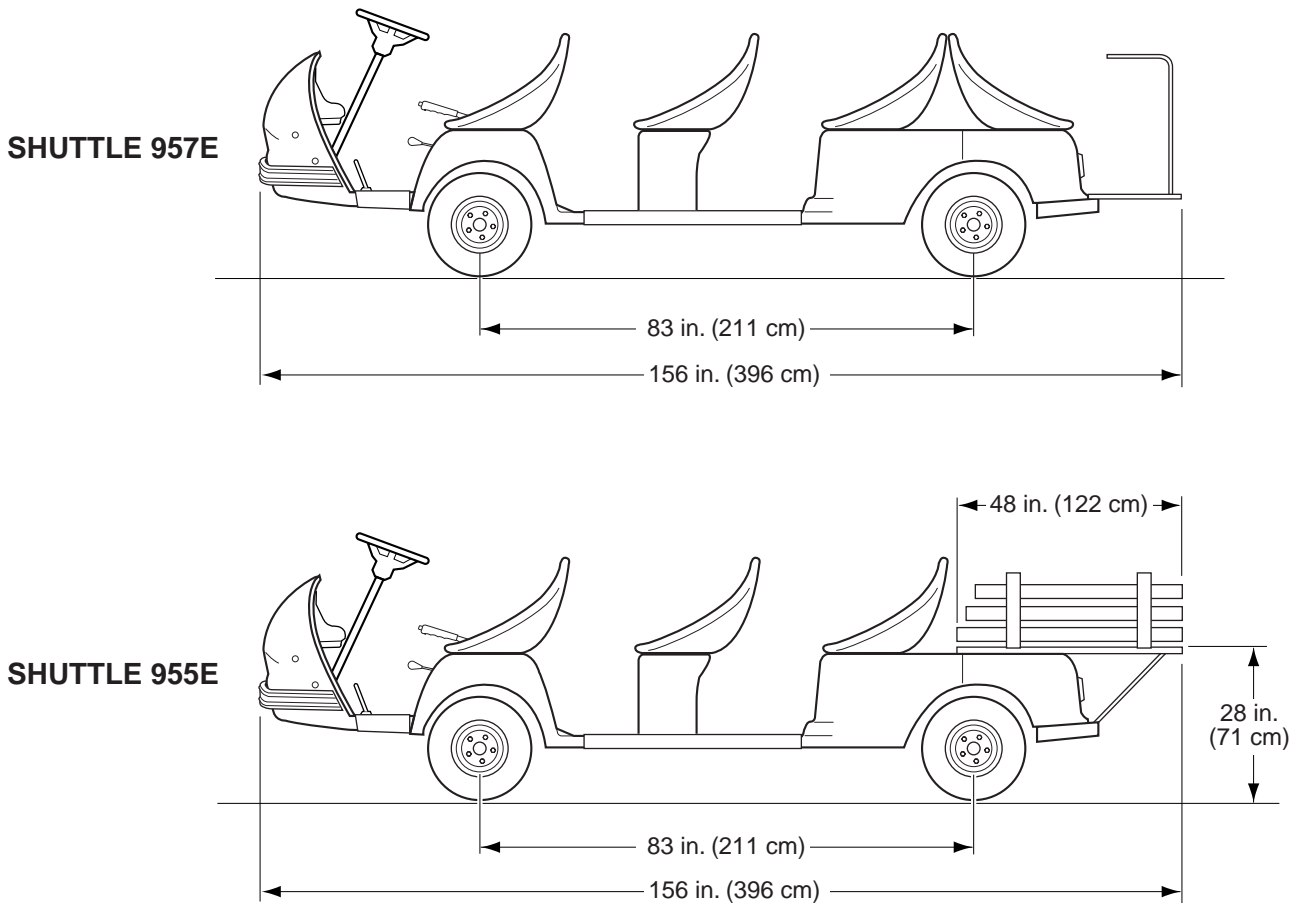
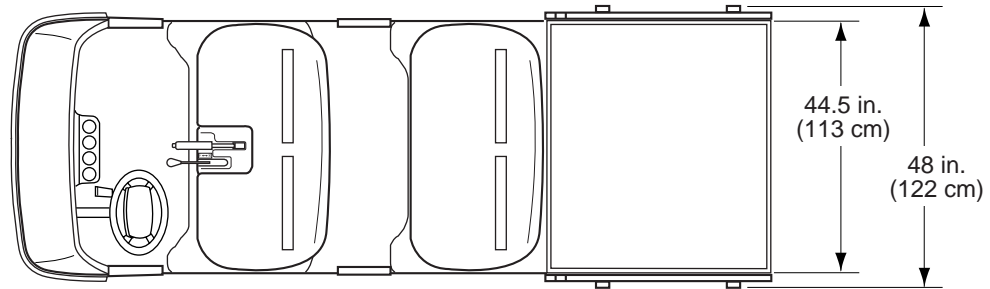
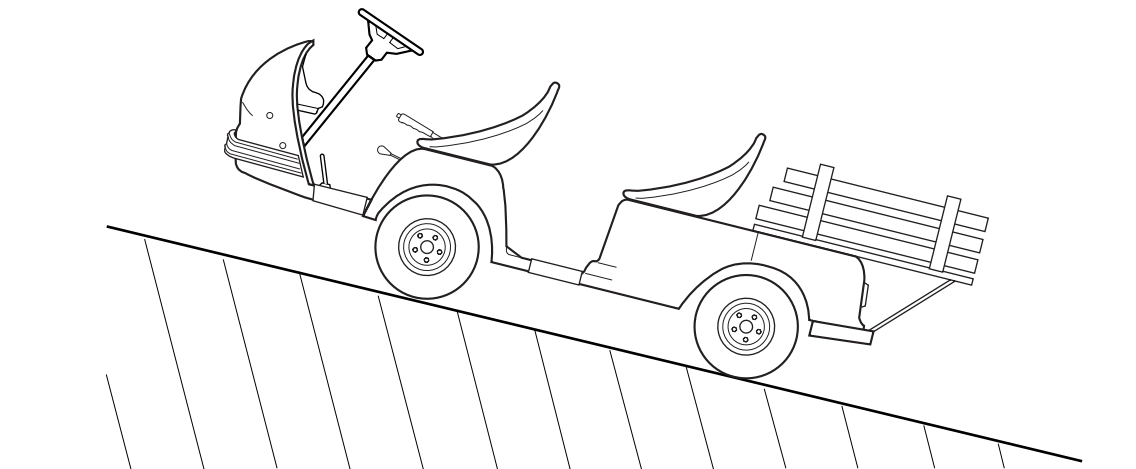
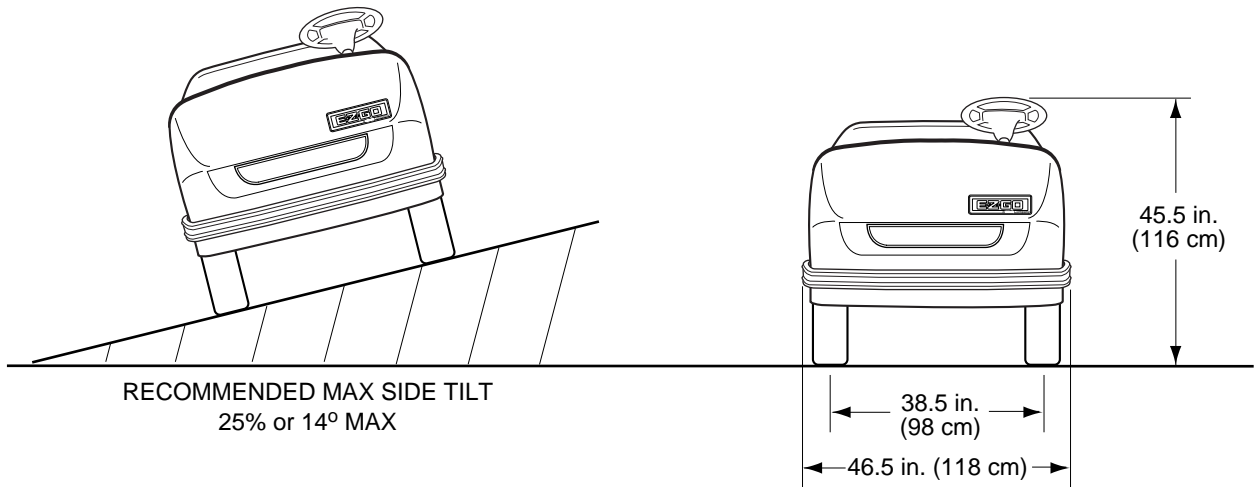

Fig. 30 955 and 957 Vehicle Dimensions

GENERAL SPECIFICATIONS



NOTE: SHUTTLE 954E shown - same for SHUTTLE 952E and 955E



RECOMMENDED MAX RAMP GRADE
25% or 14° MAX

NOTE: SHUTTLE 954E shown - same for all models

Fig. 31 Vehicle Dimensions and Incline Specifications

GENERAL SPECIFICATIONS

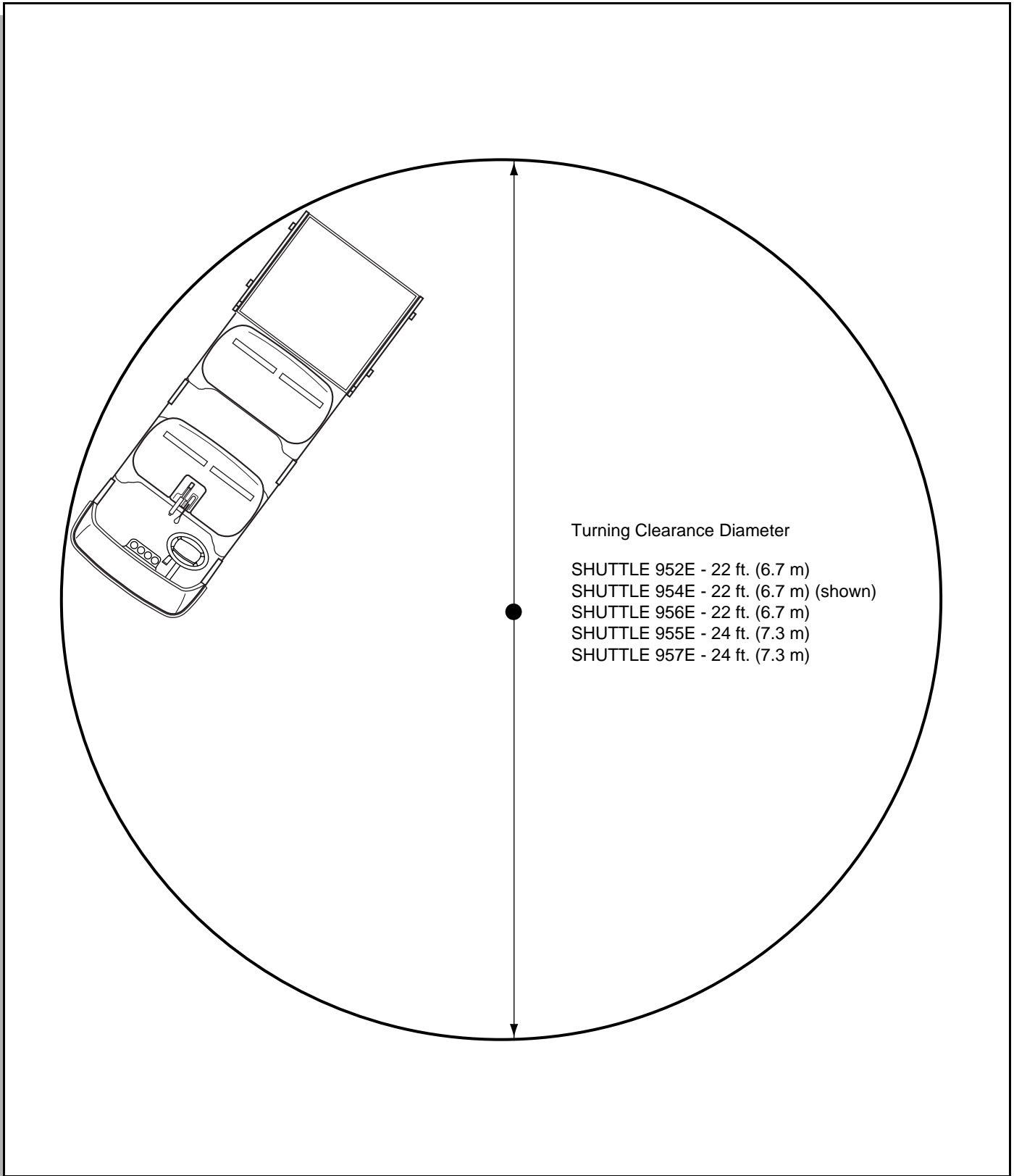

Fig. 32 Vehicle Turning Clearance Diameter

NOTE

Read and understand the following warnings before attempting to operate the vehicle:



To prevent personal injury or death, observe the following:

When vehicle is to be left unattended, engage parking (PARK) brake, move direction selector to neutral, turn key to 'OFF' position and remove key.

Drive vehicle only as fast as terrain and safety considerations allow. Consider the terrain and traffic conditions. Consider environmental factors which effect the terrain and the ability to control the vehicle.

Avoid driving fast down hill. Sudden stops or change of direction may result in a loss of control. Use service brake to control speed when traveling down an incline.

Use extra care and reduced speed when driving on poor surfaces, such as loose dirt, wet grass, gravel, etc.

All travel should be directly up or down hills.

Use extra care when driving the vehicle across an incline.

Stay in designated areas and avoid steep slopes. Use the parking brake whenever the vehicle is parked.

Keep feet, legs, hands and arms inside vehicle at all times.

Avoid extremely rough terrain.

Check area behind the vehicle before operating in reverse.

Make sure the direction selector is in correct position before attempting to start the vehicle.

Slow down before and during turns. All turns should be executed at reduced speed.

Always bring vehicle to a complete stop before shifting the direction selector.

See GENERAL SPECIFICATIONS for standard vehicle load and seating capacity.

NOTE

Read and understand the following text and warnings before attempting to service vehicle:

In any product, components will eventually fail to perform properly as the result of normal use, age, wear or abuse. It is virtually impossible to anticipate all possible component failures or the manner in which each component may fail.

Be aware that a vehicle requiring repair indicates that the vehicle is no longer functioning as designed and therefore should be considered potentially hazardous. Use extreme care when working on any vehicle. When diagnosing, removing or replacing any components that are not operating correctly, take time to consider the safety of yourself and others around you should the component move unexpectedly.

Some components are heavy, spring loaded, highly corrosive, explosive or may produce high amperage or reach high temperatures. Battery acid and hydrogen gas could result in serious bodily injury to the technician/mechanic and bystanders if not treated with the utmost caution. Be careful not to place hands, face, feet or body in a location that could expose them to injury should an unforeseen situation occur.



Before working on the vehicle, remove all jewelry (rings, watch,

necklaces, etc.).

Be sure no loose clothing or hair can contact moving parts.

Use care not to touch hot objects.

Raise rear of vehicle and support on jack stands before attempting to run or adjust powertrain.

Wear eye protection when working on or around the vehicle. In particular, use care when working around batteries, using solvents or compressed air.

Hydrogen gas is formed when charging batteries. Do not charge batteries without adequate ventilation.

Do not permit open flame or anyone to smoke in an area that is being used for charging batteries. A concentration of 4% hydrogen gas or more is explosive.



A Textron Company

E-Z-GO Division Of Textron, Inc.,
1451 Marvin Griffin Road, Augusta, Georgia USA 30906-3852

TO CONTACT US

North America:

Technical Assistance & Warranty Phone: 1-800-774-3946, FAX: 1-800-448-8124

Service Parts Phone: 1-888-GET-EZGO (1-888-438-3946), FAX: 1-800-752-6175

International:

Phone: 010-1-706-798-4311, FAX: 010-1-706-771-4609

Copyrighted Material
This manual may not be reproduced in whole or
in part without the express permission of
E-Z-GO Division of Textron Inc.
Technical Communications Department